



FORMULA FREE COOLING LINE

AIR SOURCE CHILLER FEATURING
FREE COOLING FUNCTION, WITH
SCROLL AND SCREW COMPRESSORS,
FROM 40 TO 1321 kW

FULL FREE COOLING
AT HIGH TEMPERATURE

OPTIMIZED FREE
COOLING MANAGEMENT

EXCLUSIVE
DEDICATED COILS

SMART
CONTROLS

 **CLIMAVENETA**
SUSTAINABLE COMFORT



WHEN COOLING DEMAND IS A NECESSITY ALL YEAR LONG

**MODERN DATA CENTERS,
TELECOMMUNICATION AND
INDUSTRIAL PROCESSES CAUSE
HIGH INTERNAL THERMAL
LOADS ALL YEAR LONG**

**CLIMAVENETA HAS
DEVELOPED ITS OWN
NO-COMPROMISE ANSWER
TO THE MAIN CHALLENGES
POSED BY THESE STRUCTURES**



USING OUTDOOR AIR FOR COOLING

When air conditioning is requested all year long, even in cold seasons, it is a shame to waste energy to produce cooling capacity when it would be just sufficient to get it from the environment. For free, for high energy saving, for a green approach to air conditioning. With a traditional chiller technology this is not possible because of its basic design that uses compressors even in cold seasons. Switching the compressors off and chilling the hydraulic circuit with the air is today's challenge number one: maximum output, minimum input.



RELIABILITY

When air conditioning is needed not only for comfort, but also for datacenter, mobile telecommunication or industrial applications, system's reliability is the first and most important prerequisite. A unit failure in units with more than 8000 hours/year of working time could cause enormous damages to the entire structure. For this reason redundancy is a common, even if expensive, practice that offers reliable systems with minimized risks. As alternative a simple unit has to be installed, minimizing the number of critical components.

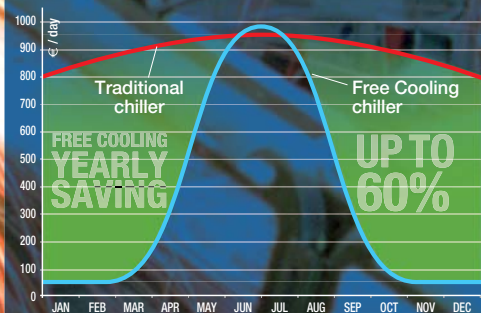

LOW OPERATING COSTS

A low energy bill is more than desired when a unit is supposed to work for most of the year. A unit's efficiency increase of only 1% in a 1 MW plant entails up to potential operating cost saving of 5.000€ per years. What about if the entire plant could more than double its efficiency? The energy bill will cut by half, and the money saved could put it towards the building itself, adding more value to it.

◀ In a datacenter with 1MW cooling capacity, energy bill can rise up to 1000€/day. Thanks to the advantages offered by free-cooling technology, the operating costs can be cut down to 50€/day during winter months, adding up to a 60% saving over the whole year, depending on the location and climate profile.



HIGHEST USE OF RENEWABLE ENERGY

More and more sustainability is the main issue that really add value to buildings. The use of green technology, in this sense, helps to gain points with the most known protocols of sustainability and moreover ensure high energy savings. When air conditioning is a constant request all year long, even during cold seasons, the air source for a chiller operation can be considered a renewable source, available wherever, with no limitations. Design a unit, capable to chill the water with the simple and direct heat exchange between the plant hydraulic circuit and the outdoor air, is the target to achieve to comply with modern requests of green technology use.

FREE COOLING

THE ULTIMATE SOLUTION
TO USE 'FREE' OUTDOOR
AIR FOR COOLING

HOW LOW OUTDOOR TEMPERATURES CAN
CHILL WATER, ENSURING TOTAL COMFORT
AND UP TO 60% ENERGY SAVINGS



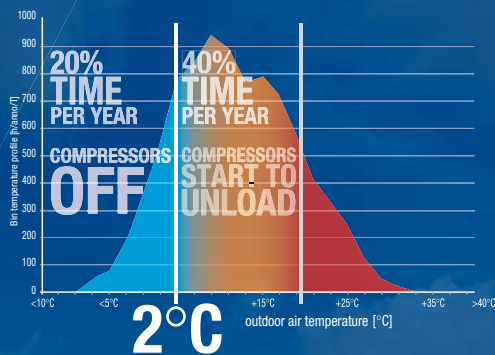

FULL FREE COOLING AT HIGH TEMPERATURE

Except for harsh climate, the most of the cities temperature profiles show a high concentration of hours per year below 2°C ambient temperature. With the latest Climaveneta Free Cooling technology, the chiller can achieve the full cooling demand without the compressors and through a direct heat exchange air/water already when air temperature drops below 2°C . A patent pending solution in the screw line FX-FC, permits to achieve this important target without compromising the chiller performance with higher outdoor air temperature.

OPTIMIZED FREE COOLING MANAGEMENT

Smart controls are the only possible way to stretch the energy saving achievable by free cooling units. The W3000 control, is able to take advantage of air free cooling potential as soon as the outdoor temperature decrease below the plant's circuit return. Therefore, the power consumption of Climaveneta Free Cooling units dramatically decrease even below 20°C outdoor temperature, which means for most of the yearly operating hours. Moreover the 'adaptive set point option' when implemented in the unit, enables a further more performance optimization: as soon as the building demand decrease, it is possible to adjust the unit set point to minimize the compressors work and thus striking more the contribute of direct free cooling. The advanced thermoregulation control grants high energy saving without compromising the system global performance.

ADAPTIVE
SET
POINT

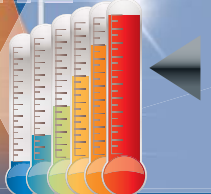

EXCLUSIVE DEDICATED COILS

The capability to have a direct and efficient free cooling is strictly related to the availability of peculiar coils where refrigerant and water reject respectively their latent and sensible heat with the highest efficiency. Climaveneta design and unique know-how grant the optimization of the unit performance both in traditional chiller and free cooling mode. A patent pending solution which moves into the direction of an effectiveness use of resources.

"EXTRA"
COIL
AIR-WATER
HEAT
EXCHANGER

CONDENSER
COIL
AIR-REFRIGERANT
HEAT EXCHANGER

SMART CONTROLS

The chilled water temperature control is always granted thanks to the advanced thermo regulation algorithms. Compressors, fans, pumps and valves are dynamically regulated to fit with the plant set point. As soon as the free cooling air contribute starts, hydraulic valves start opening and compressors and fans smoothly partialize to cover just the energy gap left by the first direct heat exchange between air and water. Climaveneta experience in Free Cooling units design is the proof of stable and precise combined resources control.



FREE COOLING MODE

The strenght point of Climaveneta Free Cooling units is their capability to manage with high flexibility and reliability the overall cooling capacity depending to each peculiar building demand and external temperature conditions.

SUMMER TIME

The water is completely chilled by the normal refrigerant cycle, using the compressor.

The Free-cooling water coil is OFF

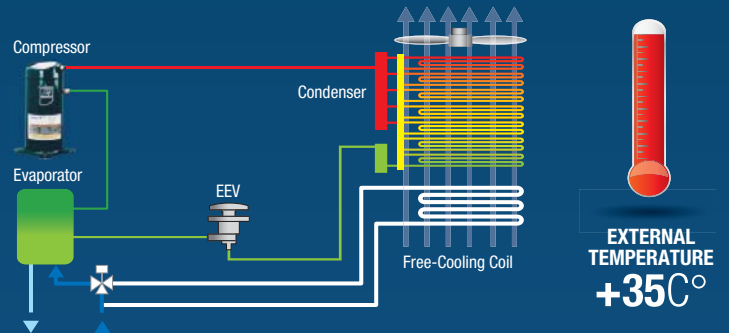

MID-SEASON

The water is partially chilled by the outdoor air, and partially by the compressor. The percentage of free-cooling obtained by the system depends on the outdoor air temperature.

A 3-way valve is used to divert the water flow through the free-cooling system. The units optimize the electrical power consumption.

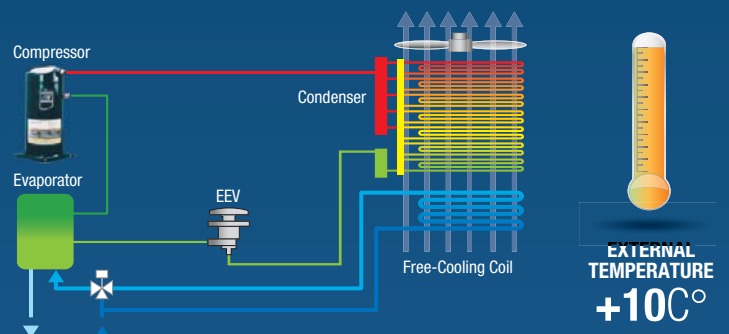

WINTER TIME

When outdoor temperature is low enough, water is completely chilled by the free-cooling coil, keeping the compressor OFF.

In this phase, the electrical power consumption is only due to the fans.

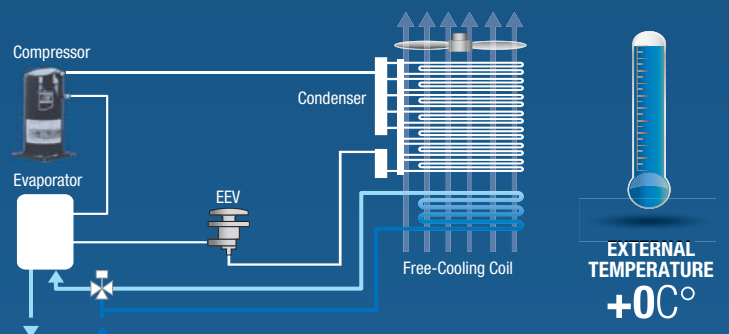

HIGHLIGHTS

DEMETRA

DEMETRA represents the solution for the most evolved and up-to-date requirements concerning the energy management of HVAC hydraulic systems. DEMETRA (DEvice for Metering of Energy TRAnsfers) in fact, enables the metering of both electric energy consumption and cooling performances; thanks to the intimate connection to each Climaveneta units controlling algorithms, with DEMETRA the final user can even measure the free cooling quote, get for free with the direct air/water heat exchanger. DEMETRA can monitor up to 8 units connected together.

DEMETRA continuously acquires the electric energy consumption, the primary circuit and outdoor air temperature, and the water flow rates on the user side heat exchanger. These values are integrated with the operating status of each unit, as detected by Manager3000 or FWS3000, to calculate the final unit performance. Thanks to the web-based structure of DEMETRA, the final user can, in every moment after authentication, access to its homepage and visualize or download the data for the relevant variables in a chiller operation.



NO GLYCOL OPTION

Operating with water directly exchanging heat with outdoor air at very low temperature, the entire primary hydraulic circuit has to be glycolated. Sometimes this is not possible or simply it is not desired. To comply with this request Climaveneta has an effective solution: the No Glycol option. A compact and unique solution which avoid the customer the issue to complicate the plant's circuitry.

SUMMER TIME

The water is completely chilled by the normal cooling cycle, using the compressor.

A dedicated heat exchanger, specifically designed to fit in the unit, hydraulically separates the glycolated and not glycolated circuits.

During hot seasons the free cooling portion of the unit is off.

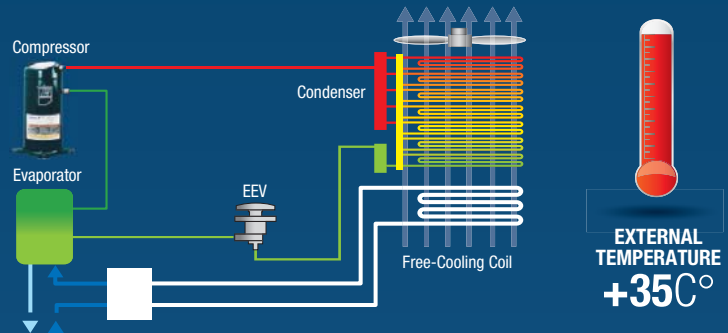

MID-SEASON

The water is partially cooled by the outdoor air, and partially chilled by the compressor. The percentage of free-cooling obtained by the system depends on the outdoor temperature.

In mid season, the intermediate heat exchange starts exchanging heat from the plant's circuit to the intermediate glycolated circuit.

The unit optimizes the electrical power consumption.

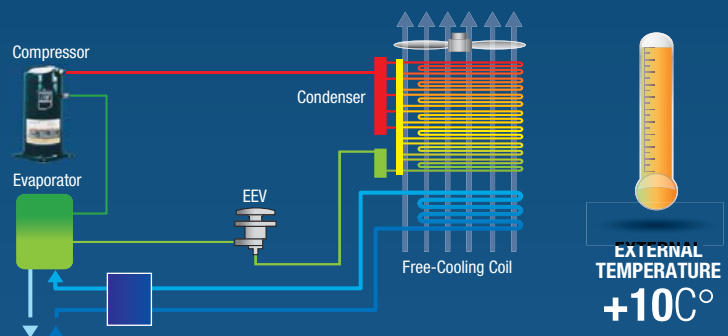

WINTER TIME

When outdoor temperature is low enough, water is completely chilled by the free-cooling coil, keeping the compressor OFF.

The entire cooling capacity is achieved thanks to the indirect heat exchange between water and air.

In this phase, the electrical power consumption is only due to the fans.

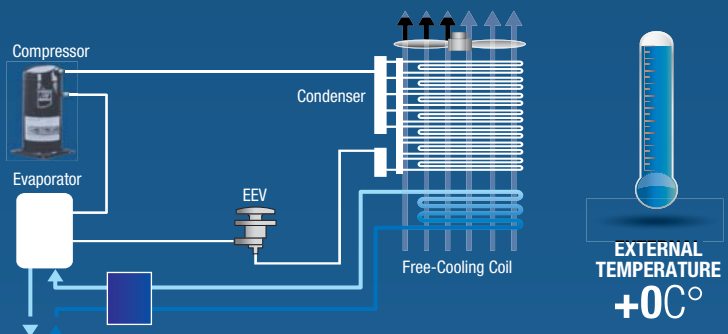

EC FANS OPTION

As known, EC fans feature a motor efficiency higher than 90% and therefore they are classified EFF-1 as per the European regulation CEMEP/EU. The superior energy efficiency of the DC brushless motor further improves the unit performance, both during summer, intermediate and winter operation.

More advantages are low inrush current and low noise. In fact, the ability to continuously adjust the fan speed

minimizes the noise level in each operating condition, load and outdoor air temperature.

Single fan energy consumption based on Paris climatic profile and an application with constant demand fans maximum speed set for a silenced version, 700 rpm. ▶

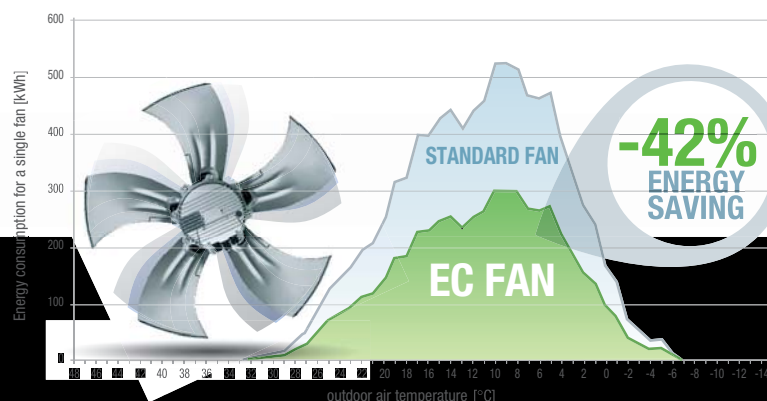

NECS-FC

HFC R-410A

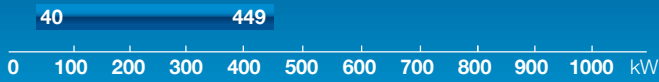

Acoustic version

B: Base
SL: Super low noise

Functions

<>: Standard
NG: No Glycol

NECS-FC				0152	0182	0202	0252	0302	0352	0412	0452	0512	0552
Compressors number				2	2	2	2	2	2	2	2	2	2
Circuits number				1	1	1	1	1	1	1	1	1	1
PERFORMANCE													
Cooling capacity	(1)	kW	B	40,6	48,2	58,2	63,6	83,2	98,2	108	123	140	156
			SL	38,2	46,9	52,5	58,8	78,5	91,5	105	114	128	145
Input power	(1)	kW	B	15,5	16,9	21,1	24,3	30,8	33,6	38,9	44,5	47,3	55,7
			SL	15,8	17,6	21,0	23,9	30,9	35,4	39,0	45,0	49,7	57,9
EER	(1)		B	2,62	2,85	2,76	2,62	2,70	2,92	2,78	2,77	2,96	2,80
			SL	2,42	2,66	2,50	2,46	2,54	2,58	2,68	2,53	2,57	2,50
Complete Free Cooling temperature	(2)	°C	B	2,0	1,6	1,3	0,5	-0,1	0,9	0,0	0,2	0,8	-0,3
			SL	-0,5	-0,9	-0,5	-0,6	-0,8	-0,6	-0,2	-0,9	-0,9	-1,1
EER in complete Free Cooling mode	(2)		B	27,1	32,1	13,9	15,1	19,8	23,4	25,7	19,6	22,3	24,8
			SL	61,6	31,3	35,0	34,2	45,6	35,5	40,6	44,1	37,1	42,0
NOISE													
Sound Power Level	(3)	dBA	B	87	87	90	90	91	91	92	92	93	93
			SL	77	78	78	79	80	81	81	82	83	84
DIMENSION													
Lenght		mm	B	2200	2200	2602	2602	2602	3602	3602	3602	4602	4602
			SL	2200	2602	2602	2602	3602	3602	4602	4602	4602	4602
Width		mm	920	920	1104	1104	1104	1104	1104	1104	1104	1104	
Height		mm	1780	1780	2175	2175	2175	2175	2175	2175	2205	2205	

NECS-FC				0604	0612	0704	0804	0904	1004	1104	1204	1404	1604
Compressors number				4	4	4	4	4	4	4	4	4	4
Circuits number				2	2	2	2	2	2	2	2	2	2
PERFORMANCE													
Cooling capacity	(1)	kW	B	167	175	195	221	252	275	316	354	404	449
			SL	155	167	180	201	226	255	291	326	375	415
Input power	(1)	kW	B	61,5	64,6	68,0	79,8	86,4	96,8	110	128	141	161
			SL	63,0	64,4	72,4	82,1	90,9	98,1	113	130	145	165
EER	(1)		B	2,71	2,71	2,86	2,76	2,92	2,84	2,87	2,77	2,87	2,78
			SL	2,46	2,59	2,48	2,45	2,49	2,60	2,57	2,51	2,58	2,51
Complete Free Cooling temperature	(2)	°C	B	2,0	-0,3	0,5	0,9	1,9	1,2	1,1	1	1,3	1,1
			SL	-1,0	-2,1	-1,0	-2,5	-1,1	-2,2	-2,5	-2,4	-2,4	-2,4
EER in complete Free Cooling mode	(2)		B	19,9	20,9	23,2	17,5	20,0	21,8	25,0	21,0	24,0	21,3
			SL	35,2	48,5	34,9	39,0	43,8	49,3	56,3	47,4	54,4	48,2
NOISE													
Sound Power Level	(3)	dBA	B	94	93	93	94	94	94	95	96	96	97
			SL	85	82	83	83	84	84	85	86	86	87
DIMENSION													
Lenght		mm	B	4602	4110	4110	4110	5110	5110	5110	5110	6110	6110
			SL	4602	4110	4110	4110	5110	5110	5110	5110	6110	6110
Width		mm	1104	2220	2220	2220	2220	2220	2220	2220	2220	2220	
Height		mm	2205	2150	2150	2150	2150	2150	2150	2430	2430	2430	

(1) Evaporator inlet/outlet temperature = 15/10°C Outdoor air temperature = 35°C Glycol content = 30%
 (2) Evaporator outlet temperature = 10°C 100% of cooling capacity Glycol content = 30%
 (3) Sound power level based on measurements in compliance with ISO3744.

FX-FC

HFC
R-134a

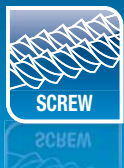

Acoustic version

T+: High efficiency
SL-T: Super low noise, high efficiency

Functions

<>: Standard
NG: No Glycol

FX-FC				1502	1702	1902	2002	2202	2602	2702	3002	3202
Compressors number				2	2	2	2	2	2	2	2	2
Circuits number				2	2	2	2	2	2	2	2	2
PERFORMANCE												
Cooling capacity	(1)	kW	T+	311	348	403	448	496	575	619	646	701
			SL-T+	307	352	396	455	494	580	609	663	693
Input power	(1)	kW	T+	95,3	110	123	142	151	185	199	215	227
			SL-T+	96,3	104	124	138	151	180	201	208	228
EER	(1)		T+	3,26	3,17	3,28	3,15	3,28	3,10	3,12	3,01	3,09
			SL-T+	3,18	3,36	3,19	3,30	3,27	3,22	3,04	3,19	3,04
Complete Free Cooling temperature	(2)	°C	T+	1,7	1,9	1,8	1,9	1,9	2,3	2,2	1,9	2,2
			SL-T+	1,1	1,1	1,1	0,9	1,1	1,0	1,4	1,0	1,4
EER in complete Free Cooling mode	(2)		T+	25,9	21,7	25,2	22,4	24,8	24,0	25,8	26,9	25,0
			SL-T+	31,9	36,6	33,0	38,0	34,3	34,6	36,3	34,5	36,1
NOISE												
Sound Power Level	(3)	dBA	T+	99	100	100	100	102	102	102	103	103
			SL-T+	89	89	89	90	91	91	91	92	92
DIMENSION												
Lenght		mm	T+	4000	4000	4900	4900	5800	5800	6400	6400	7000
			SL-T+	4000	4900	4900	5800	5800	7000	7000	7900	7900
Width		mm		2260	2260	2260	2260	2260	2260	2260	2260	2260
Height		mm		2500	2500	2500	2500	2500	2500	2500	2500	2500

FX-FC				3402	3602	3902	4202	4502	4802	5402	6002	
Compressors number				2	2	2	2	2	2	2	2	
Circuits number				2	2	2	2	2	2	2	2	
PERFORMANCE												
Cooling capacity	(1)	kW	T+	770	818	874	938	1017	1113	1237	1321	
			SL-T+	729	814	867	906	1019	1079	1198		
Input power	(1)	kW	T+	241	264	284	295	326	340	398	442	
			SL-T+	251	264	285	304	321	345	405		
EER	(1)		T+	3,20	3,10	3,07	3,17	3,12	3,27	3,11	2,99	
			SL-T+	2,90	3,08	3,04	2,98	3,17	3,13	2,96		
Complete Free Cooling temperature	(2)	°C	T+	1,7	2,1	1,6	1,6	1,8	1,7	1,8	1,8	
			SL-T+	1,1	1,4	1,0	0,7	1,3	1,0	0,5		
EER in complete Free Cooling mode	(2)		T+	24,1	25,6	27,3	29,3	25,4	23,2	25,8	27,5	
			SL-T+	38,0	33,9	36,1	37,7	35,4	37,5	41,6		
NOISE												
Sound Power Level	(3)	dBA	T+	103	103	104	104	105	106	106	107	
			SL-T+	92	92	92	92	94	94	95		
DIMENSION												
Lenght		mm	T+	7900	7900	7900	10000	10000	11800	11800	13000	
			SL-T+	7900	10000	10000	10000	11800	11800	13000		
Width		mm		2260	2260	2260	2260	2260	2260	2260	2260	
Height		mm		2500	2500	2500	2500	2500	2500	2500	2500	

(1) Evaporator inlet/outlet temperature = 15/10°C Outdoor air temperature = 35°C Glycol content = 30%
 (2) Evaporator outlet temperature = 10°C 100% of cooling capacity Glycol content = 30%
 (3) Sound power level based on measurements in compliance with ISO3744.

'BY FAR
THE BEST
PROOF IS
EXPERIENCE'

Sir Francis Bacon
British philosopher
(1561 - 1626)



Sony Ericsson

TELECOMMUNICATIONS

SONY ERICSSON PLANT

Lund - Sweden 2008

THE DESIGNER SAYS: *ENG. MATS LUDVIGSSON*

"The end user has a stable cooling load all year around, therefore the demand was an optimized solution focused on energy saving. Energy efficiency and sound level were important criterias, therefore the units have oversized evaporators and condensers compared to standard units and they are also equipped with electronic expansion valves and EC-fans that reduce to the minimum energy consumption. Climaveneta and AQS-Produkter AB are reliable partners with high quality products and technical solutions."

PROJECT

Sony Ericsson, the joint venture between Japan-based consumer electronics maker Sony and Sweden-based Ericsson, was established in 2001 to combine the cell phone operations of both companies, to draw on the wireless technology of Ericsson, the world's leading maker of wireless network equipment, and Sony's expertise in developing popular consumer gadgetry.

CHALLENGE

A high level of functionality combined with ease of use and reliable performances were the driving forces behind the choice of the air conditioning system for Sony Ericsson office building and data center in Lund, Sweden. Increasing energy efficiency respecting the environment was the most important requirement to reduce energy consumption and CO₂ emissions.

SOLUTION

For the air conditioning system of the data center, AQS-Produkter AB selected 2 Climaveneta FOCS-FC/SL 2702 with EC-fans. This air-cooled range, fitted with FREE-COOLING coils, is adapt for installations whenever the need for cooling continues throughout the cold months, or when the external air temperature is lower than the temperature of the liquid returning from the installation. During free-cooling operation the fluid is cooled by means of the external air, thus reducing the load on the compressors or even completely substituting them. The necessary cooling capacity is therefore obtained with almost zero energy expenditure.

Designer: Mats Ludvigsson - ÅF-Infrastruktur AB
Installer: Energi & Klimatteknik i Tyngelsjö AB

Installed machines:
2 Climaveneta air cooled chillers with EC-fans and free-cooling provided by AQS Produkter AB



OTHER PROJECTS FOR KONZUM



KONZUM D.D.

2009 Zaprešić (Croatia)

Air to Air System

Cooling capacity:
950 kW

Installed machines:
1x NECS-FC, 4x
WISDOM-R GAS

SHOPPING CENTRES

KONZUM D.D. - OPOROVECKA

2009 Zagabria (Croatia)

PROJECT

Located in Zagreb, Super Konzum Shopping centre is a 6000 m² mall, providing, as all Konzum stores, high quality shopping experience to its customers and visitors.

CHALLENGE

The project of the air conditioning system was characterized by several challenges, due to a very strict regulation about noise emissions, due to the location of the building. All these challenges had to ensure ideal comfort levels and a high energy efficiency.

SOLUTION

After thorough examination of a number of alternatives, the ideal solution was reached choosing a system based on 4 i-Whisper Enthalpy combined with a NECS chiller in free cooling version. The combination of a Rooftop units with a NECS-FC units using Free-cooling allowed an average power saving of 30% compared with standard European consumption and significant advantages in terms of reduced maintenance and increased reliability.

Installed machines:

1x NECS-FC/SL 0352, 1x WIZARD 0430,
4x WHISPER ENTHALPY GAS 0454



KONZUM D.D.

2009 Ivanec (Croatia)

Air to Air System

Cooling capacity:
750 kW

Installed machines:

1x NECS-FC,
3x WHISPER ENTHALPY
GAS

1000 PROJECTS ALL OVER THE WORLD



TEATRO CAMPOS ELISEOS

2009 Bilbao - Spain

Hydronic System
Cooling capacity: 536 kW

Installed machines:
1x FOCS-FC/SL 2702



WEST GATE OFFICE BUILDINGS

2008 Bucharest - Romania

Hydronic System
Cooling capacity: 5526 kW

Installed machines:
2x FOCS-FC/SL NG 4202,
2x FOCS-FC/SL NG 4212,
1x FOCS/LN R 3602,
1x FOCS-CA/LN R 3602,
Over 550 hydronic terminals

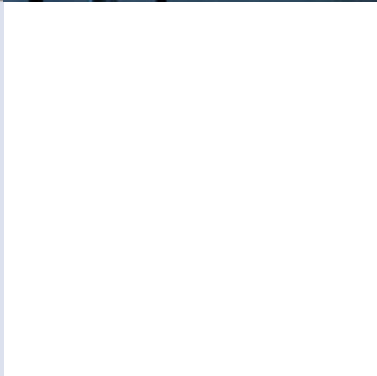
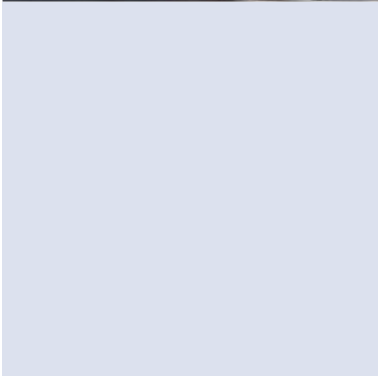

ERICUSKONTOR

2008 Hamburg - Germany

Hydronic System
Cooling capacity: 900 kW

Installed machines:
2x FOCS-FC/SL 2022,
1x NECS-W H 0512

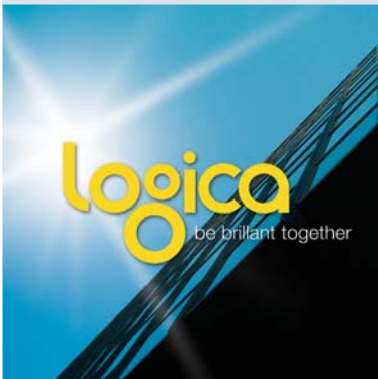

LOGICA - BROMÖLLA

2010 Bromölla - Sweden

Hydronic System
Cooling capacity: 900 kW

Installed machines:
2x FOCS-FC/SL 1922



IWC

2010 Neuhausen - Switzerland

Hydronic System
Cooling capacity: 293,1 kW

Installed machines:
1x NECS-FC 1004



IKEA STORE ÄLMHULT

2010 Älmhult - Sweden

Hydronic System
Cooling capacity: 44 kW

Installed machines:
1x NECS-FC/B 0152

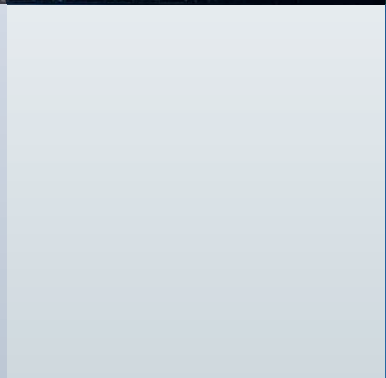
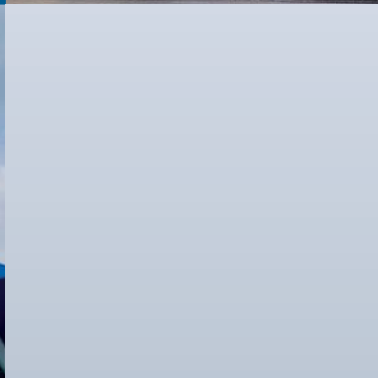

EVERY PROJECT IS CHARACTERISED BY DIFFERENT USAGE CONDITIONS AND SYSTEM SPECIFICATIONS FOR MANY DIFFERENT LATITUDES. ALL THESE PROJECTS SHARE HIGH ENERGY EFFICIENCY, MAXIMUM INTEGRATION AND TOTAL RELIABILITY DUE TO THE UNIQUE CLIMAVENETA EXPERIENCE.



EBM
2010 Münchenstein - Switzerland

Hydronic System
Cooling capacity: 56,9 kW

Installed machines:
1x NECS-FC/SL 0202



UNILEVER FOOD SOLUTIONS

2009 Poznan - Poland

Hydronic System
Cooling capacity: 900 kW

Installed machines:
2x FOCS-FC/B 1922



**MAINZ UNIVERSITY
NUCLEAR CHEMISTRY
DEPARTMENT**

2009 Mainz - Germany

Hydronic System
Cooling capacity: 240 kW

Installed machines:
1x NECS-FC/SL 1004

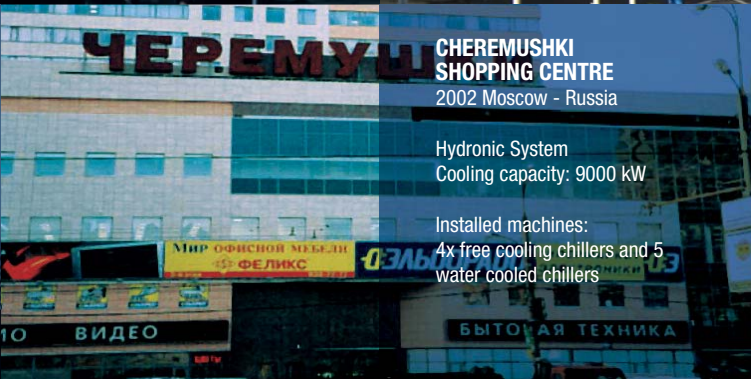

**CHERMUSHKI
SHOPPING CENTRE**

2002 Moscow - Russia

Hydronic System
Cooling capacity: 9000 kW

Installed machines:
4x free cooling chillers and 5
water cooled chillers



**NOVO PARK
OFFICE BUILDINGS**

2009 Bucharest - Romania

Hydronic System
Cooling capacity: 3614 kW

Installed machines:
2x FOCS-FC/B NG 4822, 1x
FOCS/B 4822, controlled by group
device MANAGER 3000



**NEW YORK HOTEL
DISNEYLAND PARIS**

2010 Paris - France

Hydronic System
Cooling capacity: 2899 kW

Installed machines:
2x FOCS-CA/LN D 5424,
1x NECS-FC/SL NG 0704



A Group Company of **mitsubishi electric**

Climaveneta S.p.A.

Via Sarson 57/c
36061 Bassano del Grappa (VI)
Italy
Tel +39 0424 509 500
Fax +39 0424 509 509
info@climaveneta.com
www.climaveneta.com

Subsidiaries

France

www.climaveneta.fr

Spain

www.climaveneta.es

Poland

www.climaveneta.pl

Germany

www.climaveneta.de

Great Britain

www.climaveneta.co.uk

Russia

ru.climaveneta.com

China

www.climaveneta.com.cn

India

www.climaveneta.in

Middle East

ae.climaveneta.com

Southeast Asia

www.climaveneta.com

Hong Kong

www.climaveneta.com



For more information:

www.climaveneta.com