

build your intelligent
office space with



environmental
systems
workplace

- Underfloor HVAC
- Raised Access Floor System
- Plug 'n Play Electrical Distribution
- Modular Carpet Tile



ASM
constructing smarter buildings

Manufacturer of Smart Building Products



1970s

1970s

The early years of data processing and new requirements for raised flooring. ASM Management Team begins manufacturing aluminum flooring systems for distribution across North America.

1980s

1980s

ASM Management Team expands floor line to include a full metal clad woodcore product. To date, this same woodcore product is the most widely used in the world.

1990s

1990s

ASM Management Team expands to steel panel production and grows distribution partnerships with quality flooring specialists across North and South America.

2000

2000 and on...

The culmination of over 75 years of access flooring design, manufacturing, distribution and installation to provide North America's premier office floor systems.

ASM introduces



Building on a successful and innovative past, ASM has developed the Environmental Systems Workplace™ (ESW). ESW is the culmination of proven technologies, adapted to the demands of today's rapidly changing work environment. Designed for the workplace of the information age, advanced communications, for tomorrow and beyond.

ESW completely integrates the technological requirements of occupant health and comfort, and environmental efficiencies into one cost-effective and ultimately flexible system.

For the boardroom to the classroom, and all applications in between, ASM's new Environmental Systems Workplace just makes sense.

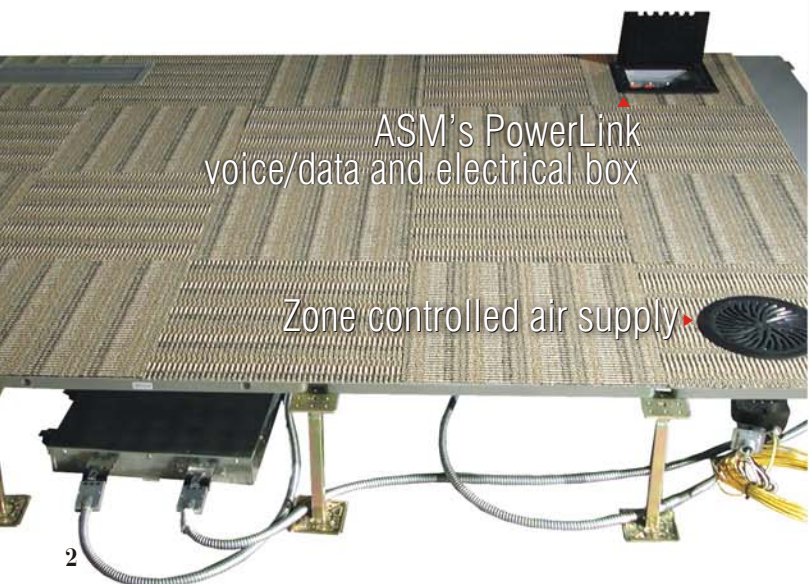

- lower building costs
- lower running costs
- lower tenant turnover costs
- environmentally friendly
- clean air technology
- energy efficient
- flexible zone air delivery system
- component wire/cable system
- optimal slab-to-slab height for low rise to high rise applications
- Cost effective
- Fully integrated

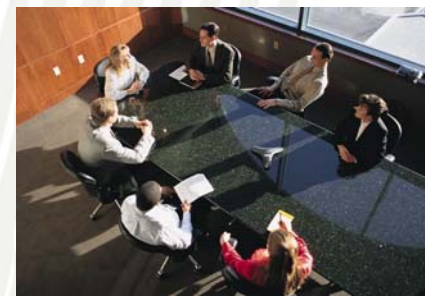

Environmental Systems Workplace It just makes sense

Around the world, innovative builders of integrated environmental systems have proven that a comprehensively designed green building improves indoor environmental quality and occupant comfort.

Over the last few decades, it's become increasingly evident that this approach provides flexibility with respect to interior changes made to the office space; saving significant resources in material, labor, operation and maintenance. In turn, waste is reduced, as are subsequent life-cycle costs, compared to conventional design.

Flexibility, Adaptability and Portability, all within an integrated environmental envelope.



Berkeley
University of California

Selected from a study published by Fred S. Bauman, P.E., and Edward A. Arens, Ph.D. 1996. Center for the Built Environment, University of California, Berkeley CA.

During recent years an increasing amount of attention has been paid to air distribution systems that individually condition the immediate environments of office workers within their workstations. The design of a majority of TAC systems has involved the use of underfloor air distribution in which supply air from a conventional air handling plant is delivered to the plenum under a raised access floor where it is allowed to flow freely through the plenum to the supply locations.

Benefits include increased worker productivity, employee retention, reduced operating costs (fewer occupant complaints), and increased market value of facilities.

Benefits

In addition to the benefits of underfloor systems described in our Technology Overview (see 'How Does It Work?'), TAC systems offer the following advantages:

- Improved thermal comfort for individual occupants
- Improved air movement and ventilation effectiveness
- Reduced building energy use
- Lower life-cycle building costs
- Improved occupant satisfaction and the potential to increase worker productivity

Advantages for the building owner

- cheaper to construct
- environmentally conscious
- energy savings
- lower tenant turnover costs
- higher building resale value
- simpler solutions to complex issues involving power, local heat load and air quality

Advantages for the tenant

- lower energy cost
- best air quality for employees and the comfort of individualized zones
- higher employee productivity

Build your environmentally friendly building



ASM's Environmental Systems Workplace versus conventional construction

21st century construction

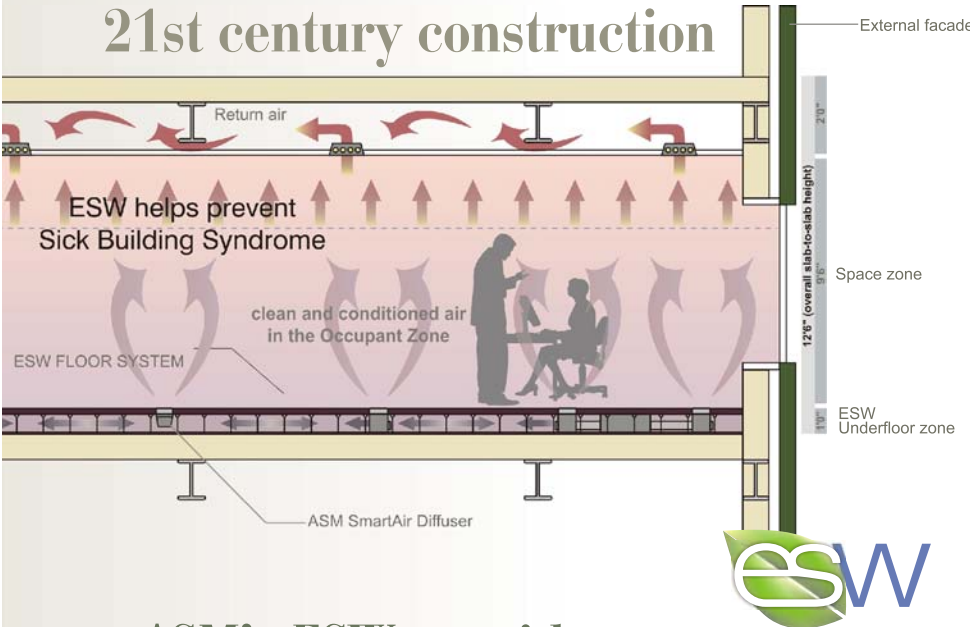

ASM's ESW provides significant overall energy savings

conventional construction

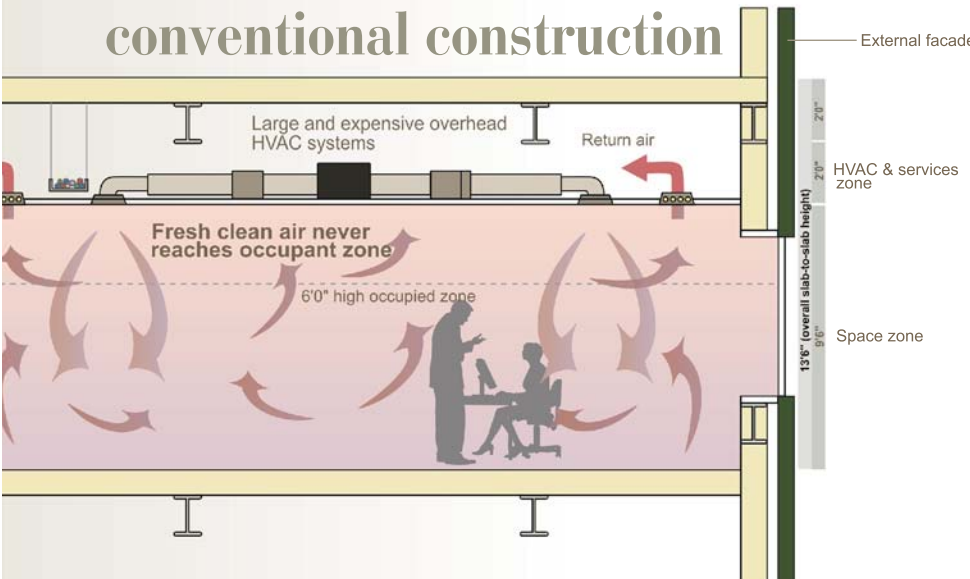

Builder/Developer Advantages are:

- reduction in initial construction costs
- reduction in height by as much as a foot per story
- reduction in building time - as much as 15% faster to build
- earlier rental as a result of faster building time
- flexibility of space increases rental opportunity
- adaptability of space prevents costly future renovations to respond to rapid technological changes
- raised flooring system & HVAC can be itemized as person property and depreciated as such

Operational Advantages are:

- reduction in HVAC plant costs
- office churn costs reduced to a quarter of conventional construction rates
- greatly reduced cost per work station or zone for
 - wiring and cable reconfiguration
 - HVAC configuration
- A significant overall energy savings
 - fan energy usage by as much as 45%
 - significant reduction in cooling energy consumption
- optimized opportunity to achieve LEED credit using underfloor HVAC and modular wiring/cabling

Staff Advantages:

- individual climate control through SmartAir diffusers
- overall enhancement of comfort and health as a result of improved air quality
- a quantifiable reduction in employee absenteeism as a result of the superior air quality
- measurable staff productivity gains because of a better working environment

A green building provides improved indoor environmental quality. It conserves significant material resources, and saves in maintenance and operation.

Integrating ESW's advantages creates a cohesive and integrated efficiency, resulting in resource conservation, waste reduction and adaptability over the life-cycles of your building.

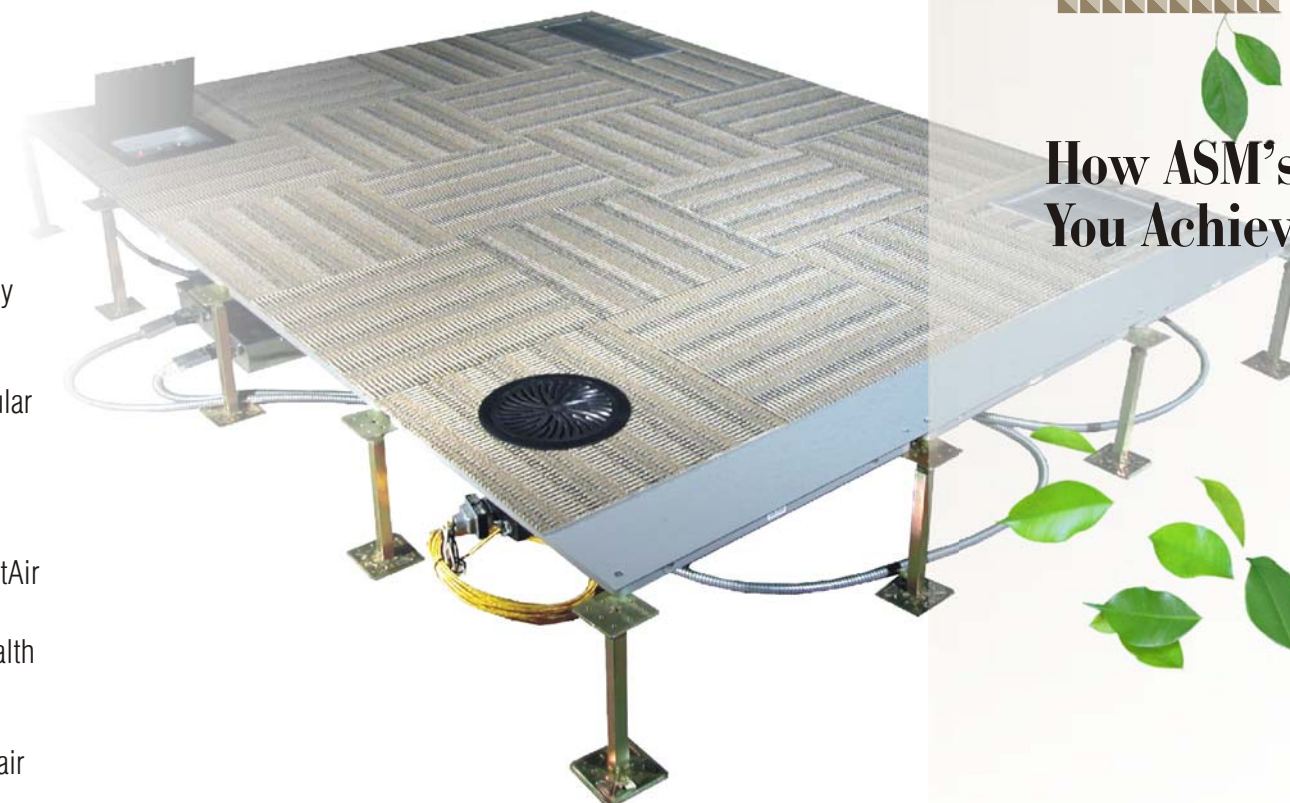

How ASM's ESW Can Help You Achieve Certification

- reduced energy costs
- reusable interior components
- recycled content of components
- improved air flow and ventilation
- improved interior air quality
- improved conservancy through optimized HVAC
- improved occupant thermal comfort
- increase in use of natural daylight
- flexibility promoting design innovation

LEED CREDIT CATEGORIES

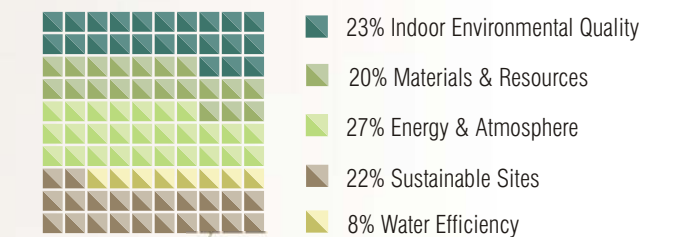

ASM's environmental systems workplace

Supreme Building Technology

Conventional office construction typically limits change of office configuration because of fixed HVAC structure, ductwork, cable conveyance, ceiling considerations and piping. ESW completely integrates the technological requirements of occupant health and comfort, and environmental efficiencies into one cost-effective and ultimately flexible system.

ASM's ESW offers a wide selection of floor coverings.



PowerLink plug and play connections for wiring not only save time and money in initial construction, but allow for quick changes and flexibility over the life of the building. See pages 10 and 11.



Electrical/Voice/Data Box

Concrete slab

Raised Floor Understructure

Zone Distribution Box - Electrical/Voice/Data

ESW allows for minimal ceiling cavities - lower slab-to-slab height between stories.

ESW's Comfort Zone System delivers fresh, clean and conditioned air with minimum mixing and maximum efficiency. ESW's underfloor HVAC allows for superior air quality, personal occupant comfort, all while lowering operating costs.



Building on a long and successful past in the manufacture and design of raised access flooring, ASM has developed the Environmental Systems Workplace. The latest in a long history of innovation, ASM introduces ESW - the culmination of proven technologies adapted to the demands of today's rapidly changing work environment.

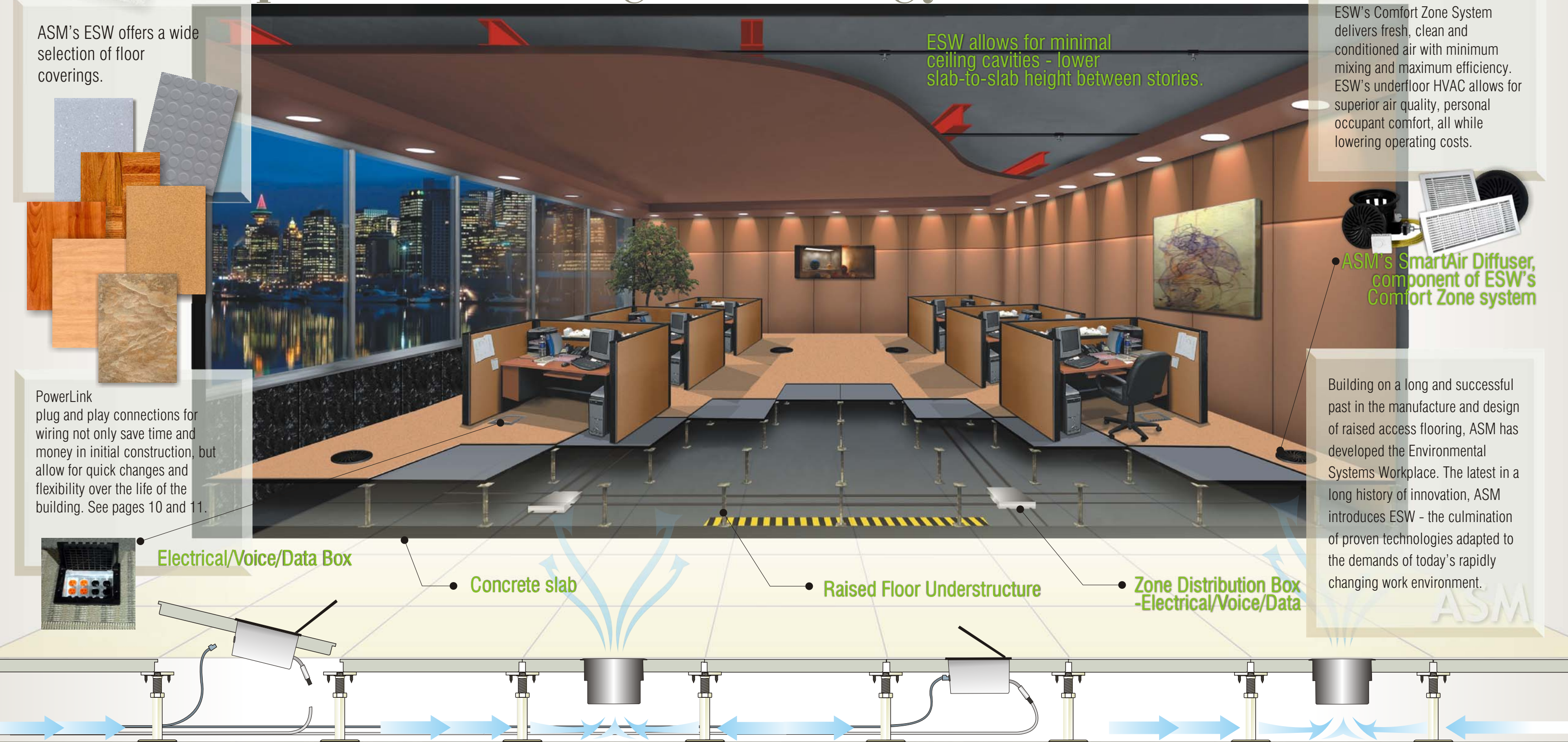

Optimized HVAC with access floor as plenum

significant overhead ductwork savings

The optimal delivery of clean and conditioned air into the workspace is under the floor, delivered by a system of components so flexible it can be rearranged or added in minutes.

It can reduce the overall energy consumption of a building by up to 20%. Natural convection currents reduce fan energy use by upwards of 32%, and reduce cooling energy expenditures by 15%.

ASM's "Comfort Zone" air delivery system uses raised access floor and temperature controlled zone air diffusers and grilles for ultimate air quality and comfort.

ESW delivers fresh, clean and conditioned air with minimum mixing and maximum efficiency. ESW's underfloor HVAC allows for superior air quality, personal occupant comfort, all while lowering operating costs.

flexibility. Air outlets are very simple to relocate.

ESW's 100 CFM SmartAir Diffuser comes with temperature controlled actuator for ultimate personal climate control.

Without costly ductwork to dismantle or replace during the reconfiguration of a workspace, underfloor HVAC offers unprecedented

Variable air volume terminals help avoid the common problem of puddling of cold air in the low load areas of buildings.

ASM VAV Terminal 150 cfm



ASM SmartAir Diffuser



ASM SmartAir Diffuser 100cfm with actuator



ASM SmartAir Diffuser 100cfm with actuator



ASM Thermostatic Control



- Save up to 20% in energy costs versus overhead HVAC VAV systems

- Convection and air displacement stratify stale air at ceiling level resulting in a healthier work place

- Better thermostatic regulation of temperature for better comfort control

- Fresh air displaces stale air

- Ventilation is 150% more effective than with conventional HVAC VAV systems

- It requires over 40% less fan energy to deliver 65°F air via ASM's ESW plenum

- Improved Indoor Air Quality in the occupant breathing zone

- Efficient use of partially reheated bypass air

- Stratifies excess heat and pollutants more effectively

- Varying air volume supplies only enough air to meet occupant comfort, thereby reducing fan energy requirements

- Low pressure plenum requires less energy to power fan

- Diversity of the cooling load of building means air handling units and chillers can be downsized



ASM's PowerLink plug 'n play electrical distribution delivers ultimate technology-friendly advantages

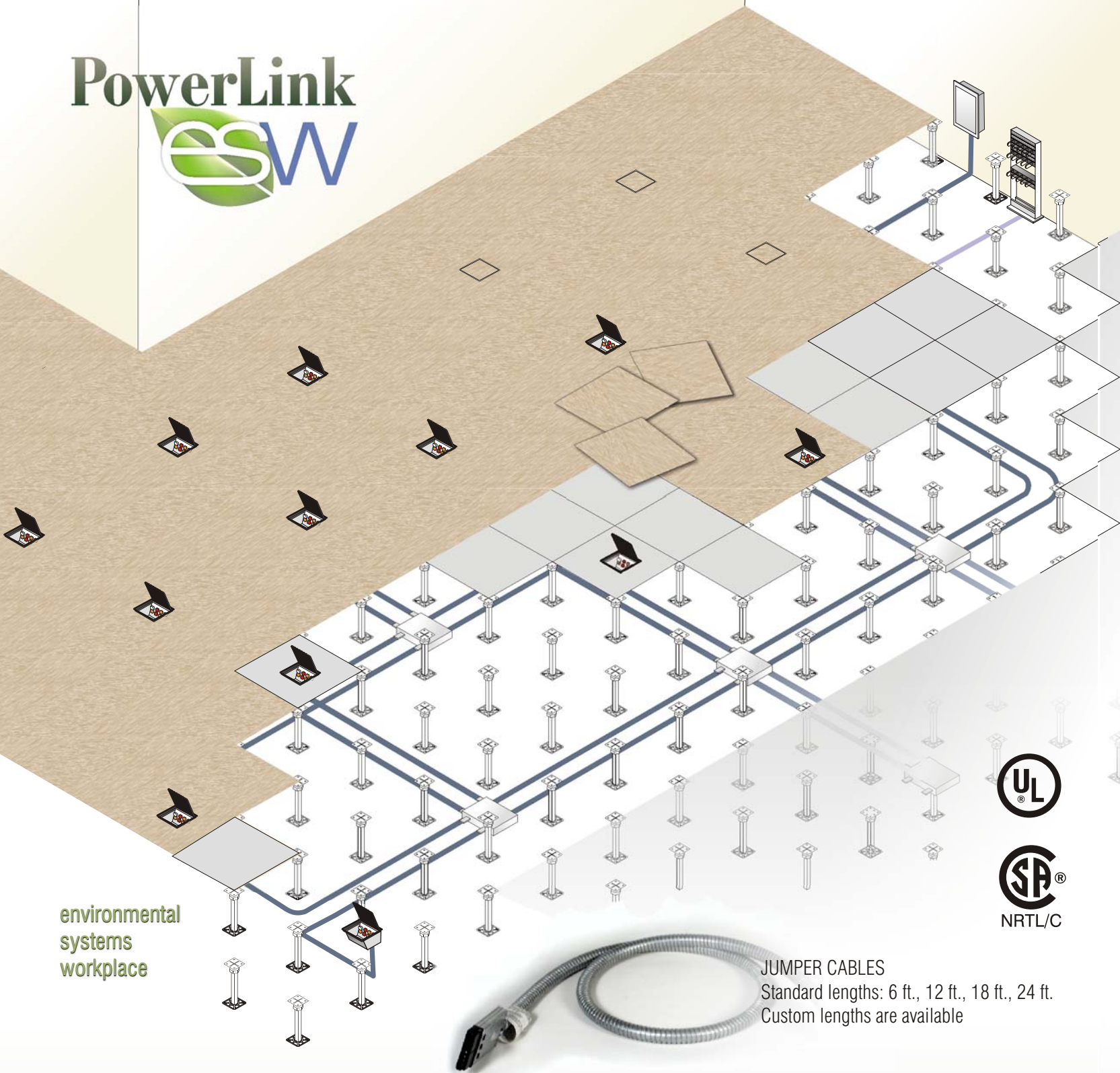

environmental systems workplace



JUMPER CABLES
Standard lengths: 6 ft., 12 ft., 18 ft., 24 ft.
Custom lengths are available



Modular Wiring systems provide ultimate flexibility and accessibility in terms of telecom/data services and power connection configurations.

Engineered using a completely portable "zone" approach, modular wiring can be adapted and changed easily, and without disturbances to phones, computers and power to other users on the system. Office space can be expanded or modified quickly and conveniently - a huge cost savings over the life-cycle of a building.

fully integrated and interchangeable zone management of phone, data management and power systems

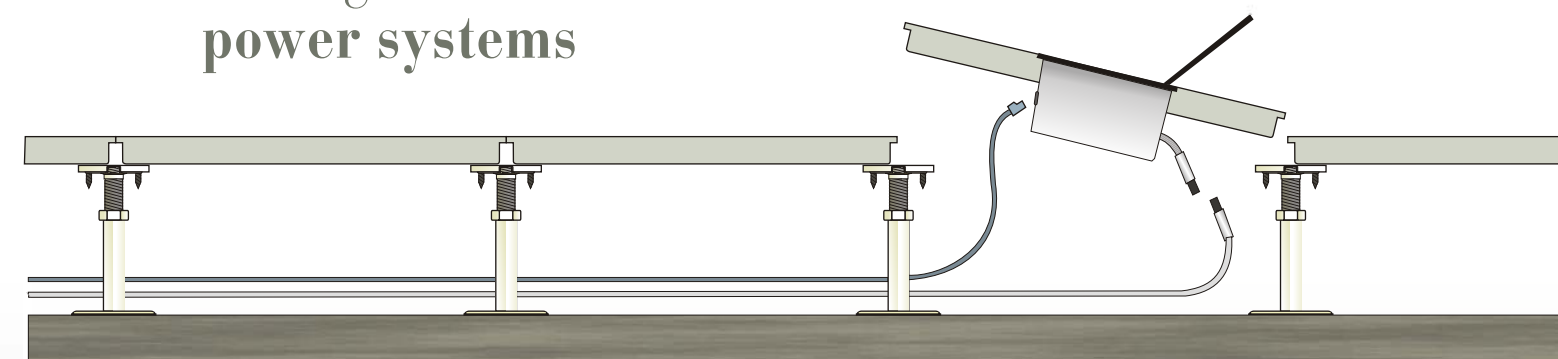

Standard electrical/voice/data



Zone Distribution Box

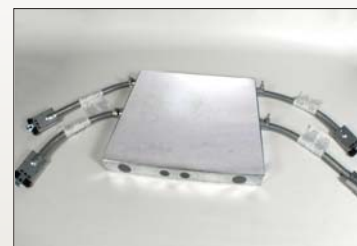

Installed Zone Distribution Box

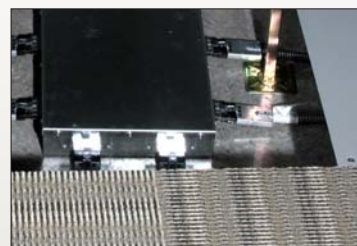

Zone Distribution box



Low Profile Electrical/Voice/Data Box



Installed Electrical/Voice/Data Box



ASM's environmental systems workplace

A comprehensive system for new builds.
And a renovation solution.

Underfloor HVAC

Raised Access
Floor System

Plug 'n Play
Electrical Distribution

Modular Carpet Tile



From boardroom to classroom



Businesses have responded quickly and dramatically to rapid technological changes over the last several years. Yet, building systems have been slow to accommodate these demands. Changes to conventionally constructed offices, institutions and data centers continue to be disruptive, slow and wasteful. Repairs are unnecessarily costly and labor intensive.

ESW eliminates the need for embedded wiring and provides instant access to wiring and cabling, allowing for quick and easy reconfiguration. Low cost, and no waste.

Demands of the marketplace are not limited to accommodation of voice and data technologies, however. There has been a growing trend toward environmentally friendly building, and energy efficiency. ESW takes full advantage of the principles of thermal displacement and air convection to lower operating costs and increase adaptive capacity.

Not only does ESW reduce initial construction material and labor costs, its integrated system provides ultimate zone comfort and indoor air quality for building occupants.

**ESW: fully integrated, efficient,
flexible, cost effective.**



Lower Construction
Costs

Lower Running Costs

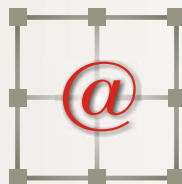

ASM
constructing smarter buildings

U.S.

9500 Industrial Center Drive
Ladson, South Carolina
29456
(843) 534-1110
(843) 534-1111 Fax

Canada

2880 Argenta Rd., Unit #3
Mississauga, ON L5N 7X8
(905) 819-5000
(905) 819-8839 Fax

www.asmproducts.com