

# ASM

innovations in access flooring



## Data Center

# The New Standard in Data Center Design... ASM H-D System

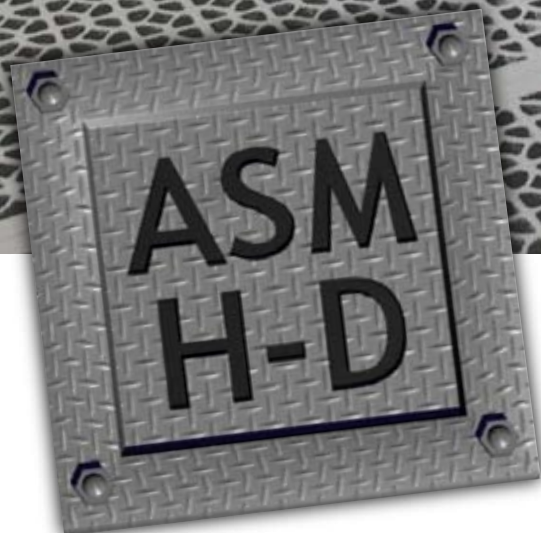

U.S.A. Engineered Products  
U.S.A. Quality & Testing  
Global Vision





## ASM's Enviro Panel:

Most widely used panel design in the world



ASM's High Strength  
Welded Steel  
Cement Filled Floor Panel

# High Strength Corners

High strength cement fill, along with steel designed in the corners where it is needed, gives ASM the best corner panel loading in the industry.

- ☒ Strongest panel design in the world
- ☒ Full formed corner design for H-D performance
- ☒ Deep drawn technology for rigorous testing

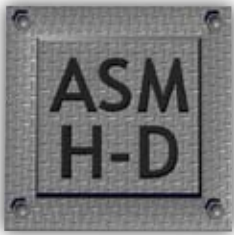

## RAISING THE BAR

### Ultimate (Ult) Load Capacity

The point of failure or collapse is the single most important indicator of performance. ASM products lead the industry with a minimum 2.5 safety factor for ultimate loads and design loads.



Kingspan Group PLC is a publicly traded company, specializing in the manufacture and sale of innovative building materials and components. Rigorous quality control systems and procedures ensures ASM produces only the highest quality products. ASM is a long-standing member of CISCA.



ASM's Director of Engineering, Jim Scissom, is a senior member of the CISCA Access Floor Committee with over 30 years in the raised access floor industry. He has dedicated the majority of his career to the research and design of new and innovative access floor systems.

## ASM H-D Projects

- Quality Technology Services (QTS)
- BCBS - Tennessee
- Hewlett-Packard
- Yahoo
- EMC<sup>2</sup>
- AT&T
- T-Mobile
- Numerous Gov't Facilities
- US Army
- US Navy
- US Marines
- US Air Force
- US Coast Guard
- Homeland Security
- Google

## Seismic Pedestal Systems

All of our Data Center pedestals are hot dipped galvanized and nickel chrome plated to eliminate the growth of zinc or tin whiskers. Heavy Duty Pedestal Systems are utilized to support the enormous investment of equipment placed on top of the raised access floor. Compromising for an inferior pedestal system is not worth the investment risk.



# ASM's H-D System

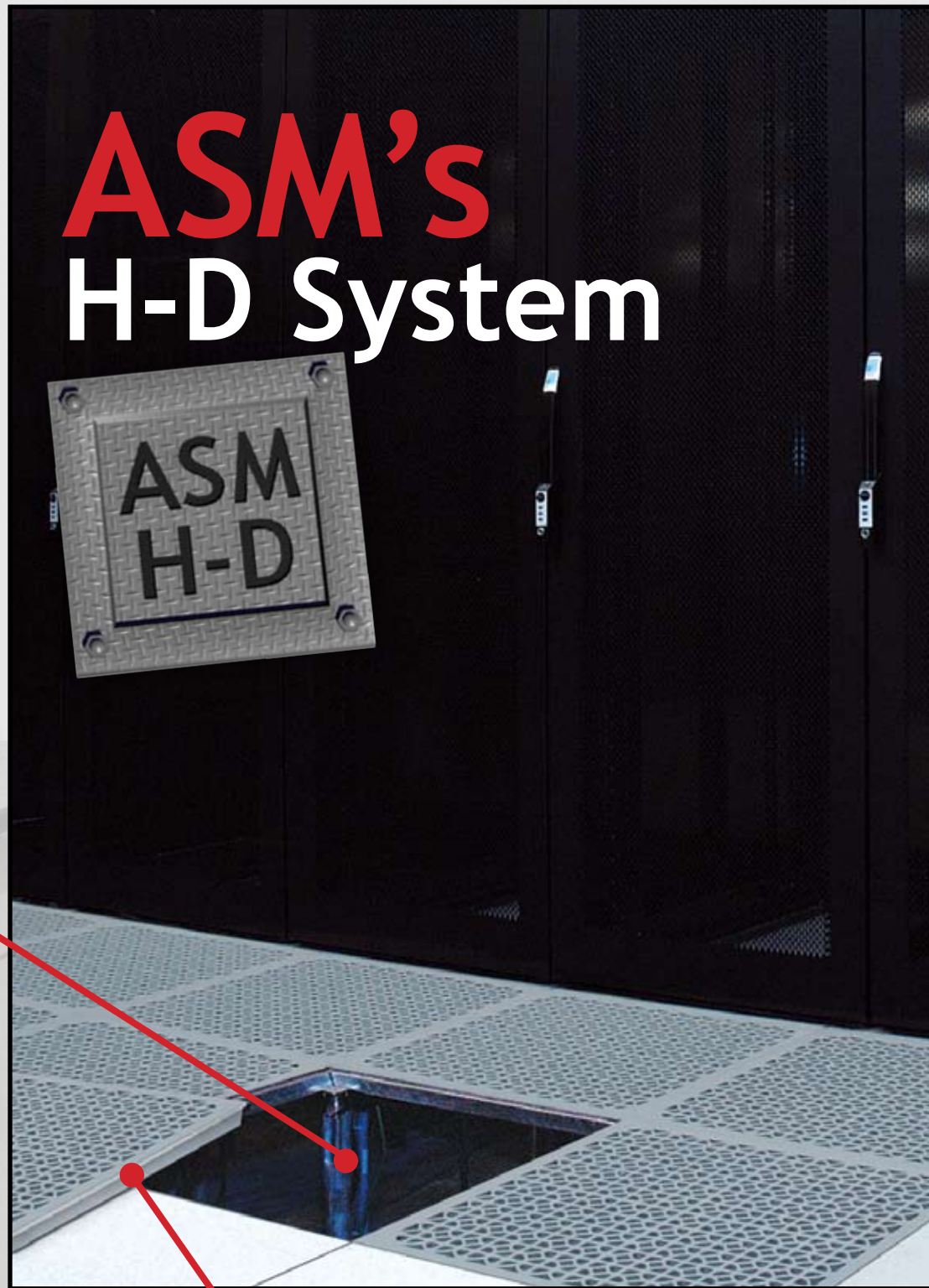

## AF600 (6000 lb Ult Load) H-D Grates

The strongest in the industry, the AF600 has a design load of 3000 lbs per square inch while maintaining an open area of 56%. The AF600 is the new standard

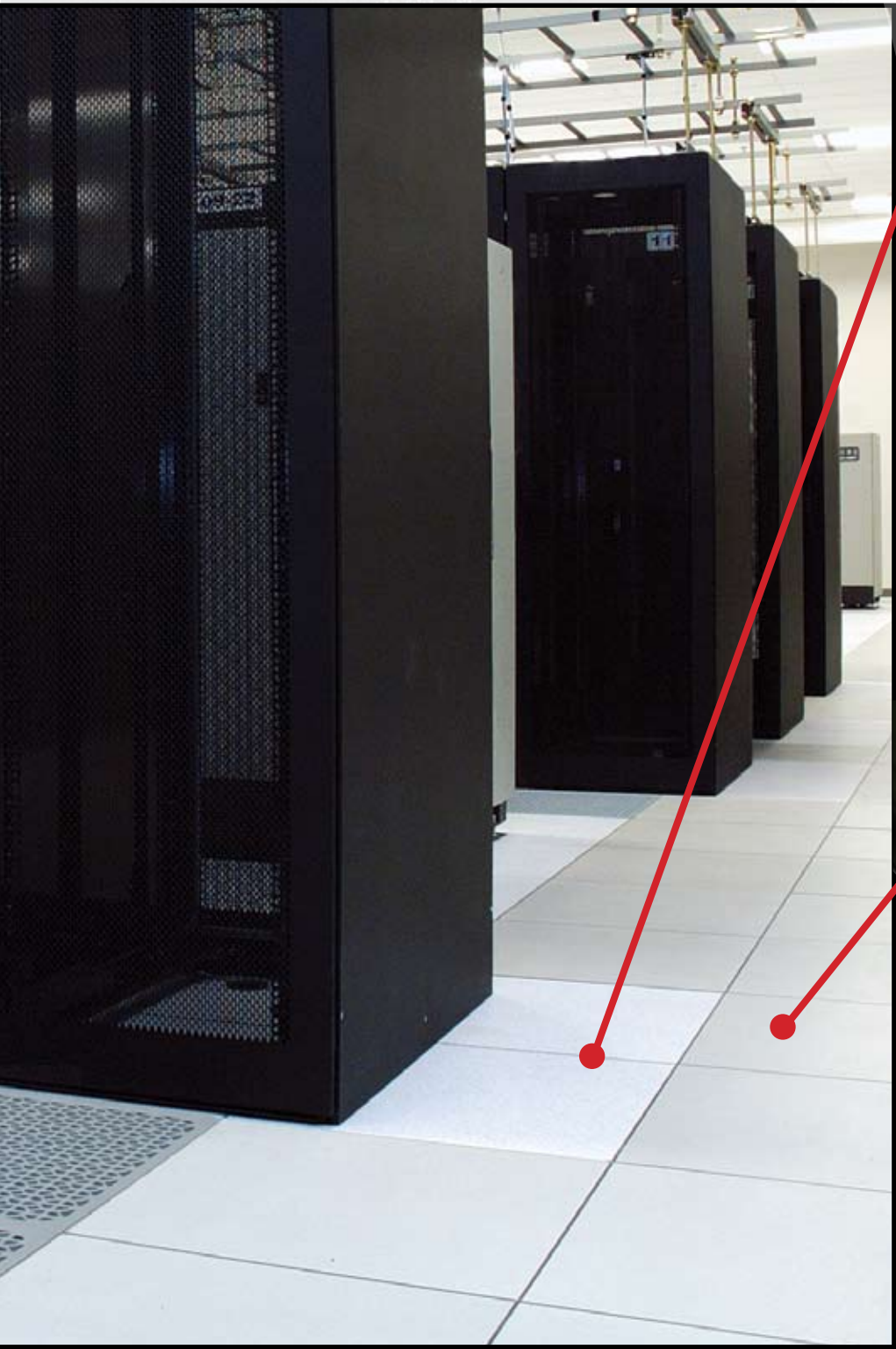

## FS300 Panel (5400 lb Ult Load)

Data Center design has jumped leaps and bounds in the last 10 years. New design increases the raised floor requirements to new levels. Field areas, where equipment and cabinets are located, now utilize medium to heavy duty rated panels to address the static load of operational equipment.

## FS600 H-D Panel (10,000 lb Ult Load)

The ASM FS600 is the industry's only 10,000 lb rated panel and ensures strength and stability for all equipment during critical moves.

Given the increasing cost of equipment being placed on the raised access floor, the floor system has been upgraded in the aisles and corridors where equipment will be moved.

The tile color is changed to offer a visual reference which allows clients and facility managers a "quick reference" as to where the heavy duty access floor system has been installed.

in air flow to compliment the heavy duty access floor systems that have become the basis-of-design in today's Data Centers.

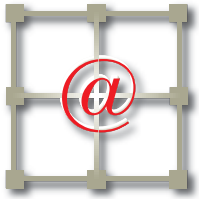

**ASM**  
innovations in access flooring

Industry's **ONLY**  
**10,000 lb Panel**



## **FS600 Enviro-Panel Concrete Filled Welded Steel Panel**

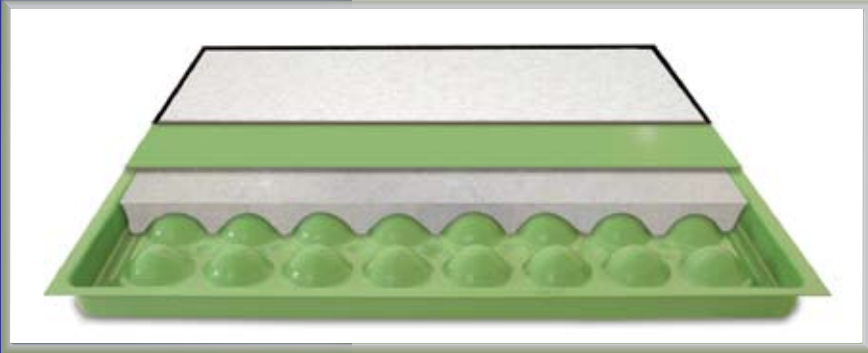

**First Ever 10,000 lb Rated  
Concrete Filled Panel:  
A Breakthrough For The  
Access Flooring Industry**

ASM is proud to announce a breakthrough in our steel panel design, allowing the creation of the first 10,000 lb ultimate load cementitious filled welded steel panel. We have engineered the new FS600 to support a 3,000 lb design load with rolling loads in excess of 2,500 lbs when tested per CISCA. Data Centers and manufacturing facilities now have an affordable option to address the ever increasing equipment loads being placed on the access floor.



- ***Environmentally friendly***
- ***Stronger***
- ***High strength corners***
- ***Can be utilized in all ASM Access Flooring Systems***

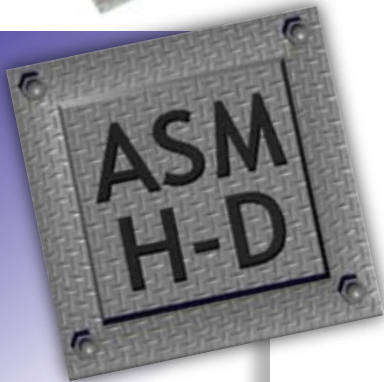

With the ever increasing weight and value of Data Center equipment, the ASM FS600 is the new standard for your Data Center foundation.

ASM continues to raise the bar by leading our industry in system solutions while providing piece of mind for our customers.

Please contact an ASM representative at 843-534-1110 for testing data and product samples.

# FS-Series Enviro-Panel Concrete Filled Welded Steel Panels

Our best seller, the FS-Panel system, is constructed of a welded structural steel assembly designed to accommodate ultimate and dynamic loads. Our specially formulated cement fill provides the end user with a solid underfoot feel, while our special powdercoat seals the panel for years of service. Panel systems are available in both 24" x 24" and 600mm x 600mm.

## ASM's High Strength Welded Steel Cement Filled Floor Panel



The Ultimate Load is considered the single most important test in the CISCA series, as it indicates when panel failure occurs.

### FS-Series Performance Guide

Panel	Ultimate Load		Concentrated Load		Impact Load		Rolling Load 10-Pass		Rolling Load 10,000-Pass	
	lb.	(kN)	lb.	(kN)	lb.	(kN)	lb.	(kN)	lb.	(kN)
FS100	3300	(14.68)	1000	(4.45)	175	(0.78)	800	(3.55)	600	(2.67)
FS200	3900	(17.35)	1250	(5.56)	175	(0.78)	1000	(4.45)	800	(3.55)
FS300	5400	(24.02)	1500	(6.67)	175	(0.78)	1250	(5.56)	1000	(4.45)
FS400	6300	(28.02)	2000	(8.90)	200	(0.89)	1500	(6.67)	1200	(5.34)
FS500	7000	(31.14)	2500	(11.12)	200	(0.89)	2000	(8.90)	1800	(8.01)
FS600	10,000	(44.48)	3000	(13.34)	400	(1.78)	3000	(13.34)	3000	(13.34)

Notes: ASM Products are tested by a certified United States testing company. Certified test reports in accordance to CISCA test procedures are available upon request.

# ASM's Air Flow Panels

## Aluminum Accel-Air Panels

### AF500 and AF600

#### Made of High Strength Cast Aluminum

For cold aisles, the Accel-Air strong and durable panel has a free open area of 56% for those applications requiring the highest cooling conditions. Accel-Air panels come standard with powder coat epoxy finish.

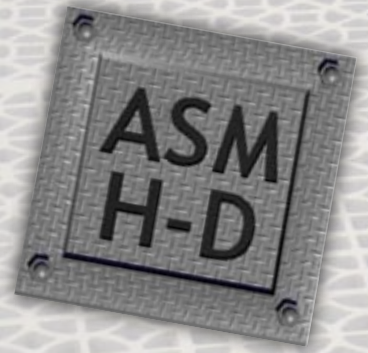
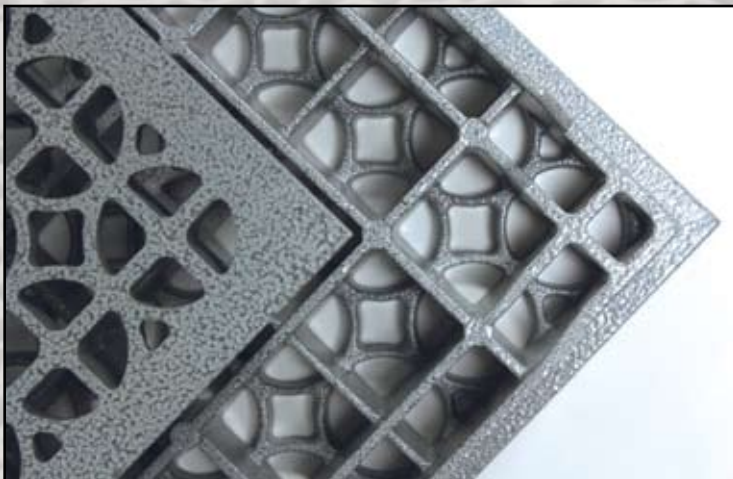

- ❑ 56% Open area for high volume air flow
- ❑ Available in 24' or 600mm size
- ❑ Available with top-adjusting slide dampers
- ❑ Completely interchangeable with FS Series and S-series panel systems
- ❑ Die cast aluminum construction
- ❑ Suitable for cleanroom applications
- ❑ Recycled material content of both AF500 and AF600 = 100%
- ❑ Conductive epoxy paint finish
- ❑ Fire rating of bare panel:

Class A Flame Spread

Non-Combustible Materials

#### AF500 PERFORMANCE DATA

- Concentrated Load rating - 1,500 lbf (6,672 N)
- Uniform Load rating - 500 psf (2,224 kg/M<sup>2</sup>)
- Ultimate Load rating - 3,000 lbf (13,345 N)  
Safety Factor - 2-to-1 Min.
- Impact Load rating - 175 lb (79 kg)
- Rolling Load rating:
  - CISCA Wheel B (10 Pass) - 1,250 lbf (5,560 N)
  - CISCA Wheel C (10K Pass) - 1,000 lbf (4,482 N)
- At 0.10 Static Pressure - 2950 CFM No Damper
- At 0.10 Static Pressure - 1400 CFM With Damper

#### AF600 PERFORMANCE DATA

- Concentrated Load rating - 3,000 lbf (13,345 N)
- Uniform Load rating - 700 psf (3,114 kg/M<sup>2</sup>)
- Ultimate Load rating - 6,000 lbf (26,690 N)  
Safety Factor - 2-to-1 Min.
- Impact Load rating - 200 lb (91 kg)
- Rolling Load rating:
  - CISCA Wheel B (10 Pass) - 2,000 lbf (8,896 N)
  - CISCA Wheel C (10K Pass) - 1,800 lbf (8,007 N)
- At 0.10 Static Pressure - 2900 cfm No Damper
- At 0.10 Static Pressure - 1350 cfm With Damper



# Standard Steel Air Flow Panels

## AF250 Steel Air Flow Panel

ASM's AF250 perforated panel is part of a series of air flow panels, has a free area of 25% and comes with or without mechanical dampers.

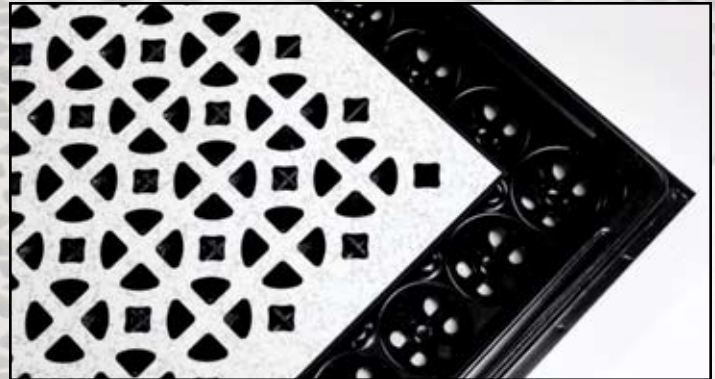

- 25% Open area for high volume air flow
- Available in 24' or 600mm size
- Available with top-adjusting slide dampers
- Completely interchangeable with FS Series and S-series panel systems
- Fire rating of bare panel:
  - Class A Flame Spread
  - Non-Combustible Materials

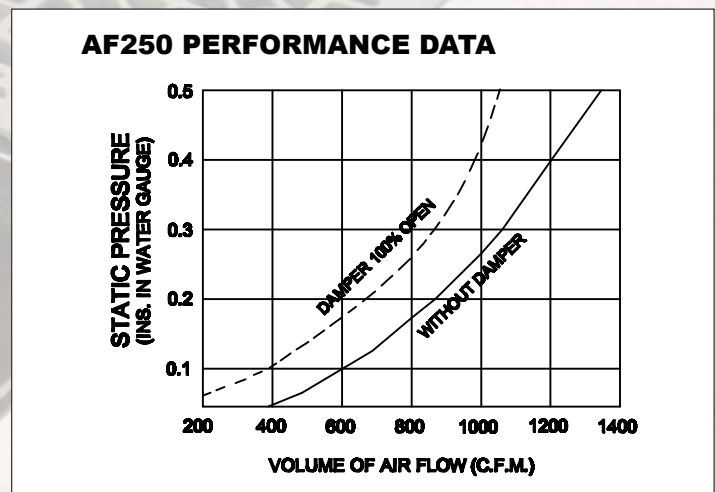

## Keeping Your Servers Cooled

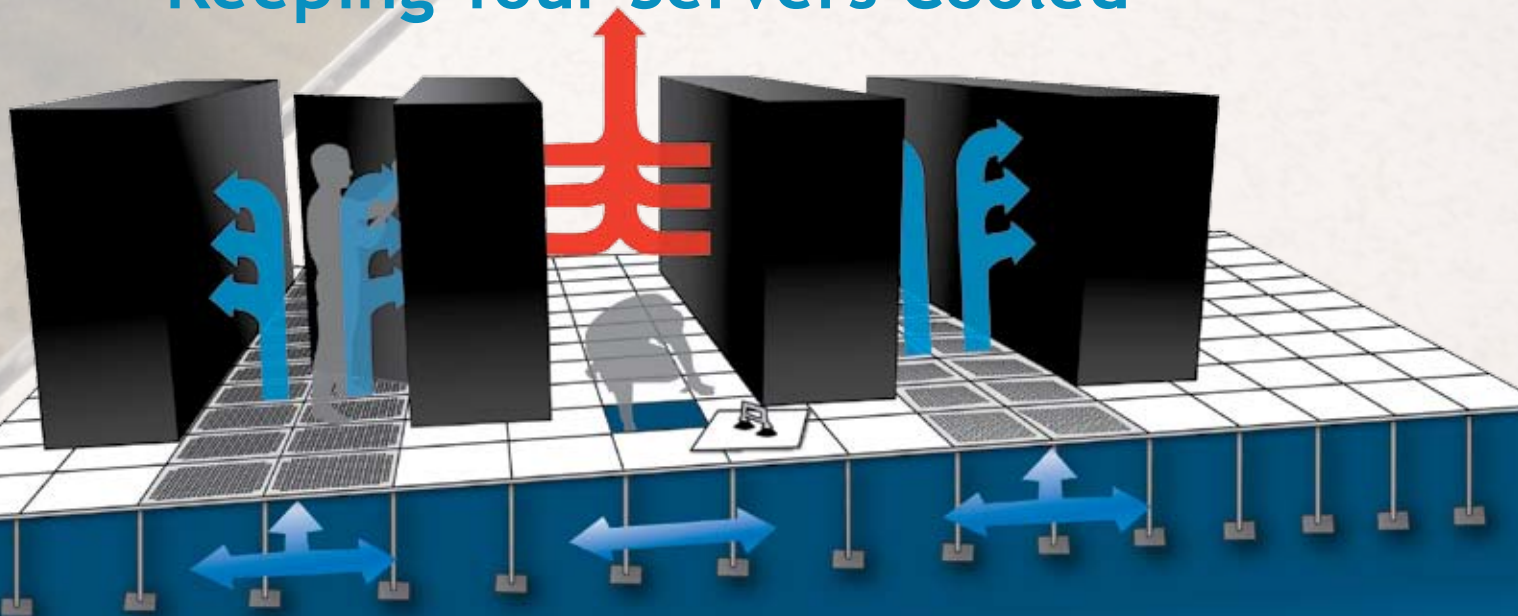

ASM's

# EQUIPSECURE

Equipment Attachment System

The New Standard, ASM's Equip-Secure attachment system is the best choice for your data center needs whether you are constructing a Non-Essential, Essential or Mission Critical building. Our vast selection of product offerings are designed for various needs based on the requirements of the facility. ASM has innovative products that have been engineered to support the most challenging load bearing requirements. The Equip-Secure System allows the equipment to be bolted directly to the access floor panels without the need to anchor down to the concrete slab.

For **Mission Critical Operation Facilities**, there is only one product ASM promotes and that is our AL8000. This is the Strongest Die Cast Aluminum Panel in the World.

- ☒ **Concentrated Load** - 8000 lbs at 0.080 Deflection
- ☒ **Rolling Load** - 10 Pass using Wheel C - 8000 lbs with a maximum Deflection of 0.006".
- ☒ **Ultimate Load** - 20,000+ lbs \*\*This was the maximum load the testing equipment could accept.

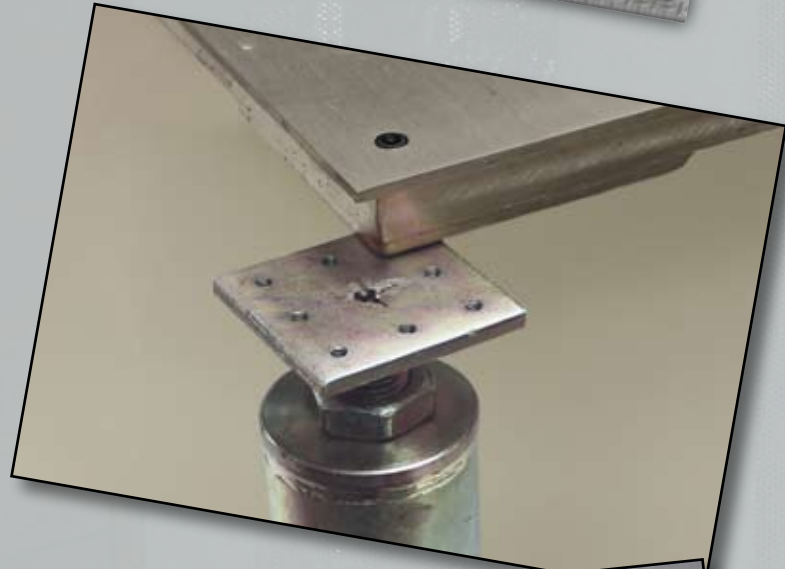
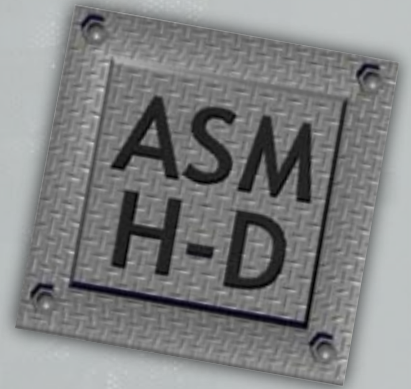

**AL8000 Equipment Mounting Plate**

Contact an ASM Equipsecure Specialist to Assist You.

# ASM offers several Panel Options for non-essential and essential facilities.

## Non-Essential Facilities

FS200, FS300 or the FS400 floor panels are medium duty and are designed to withstand severe situations when using the Equip-Secure system.

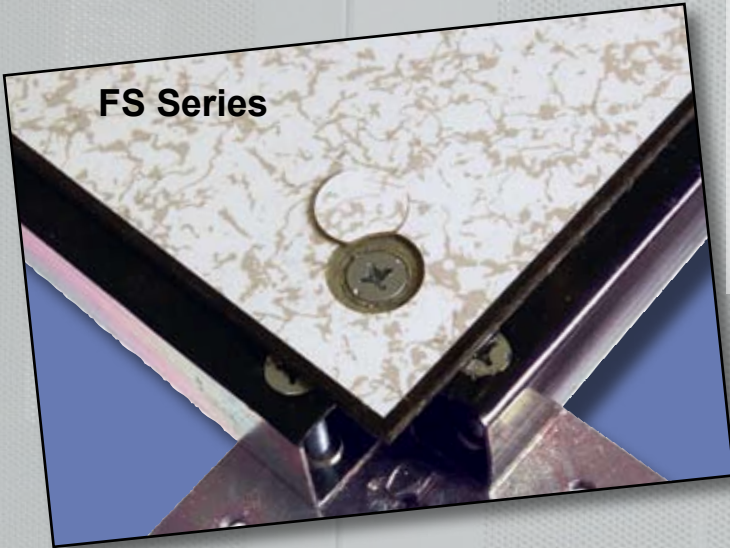

## Additional Benefits

- ❑ Save the expense of equipment stands
- ❑ Relocate equipment with ease...saving money and time
- ❑ Know your equipment is safe and secure



## Essential Facilities

FS500 and FS600 floor panels are members of the ASM H-D System and are designed to withstand extreme situations when using the Equip-Secure system in buildings that must continue to operate.

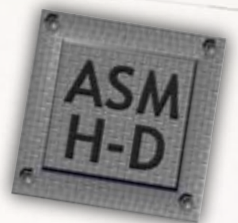
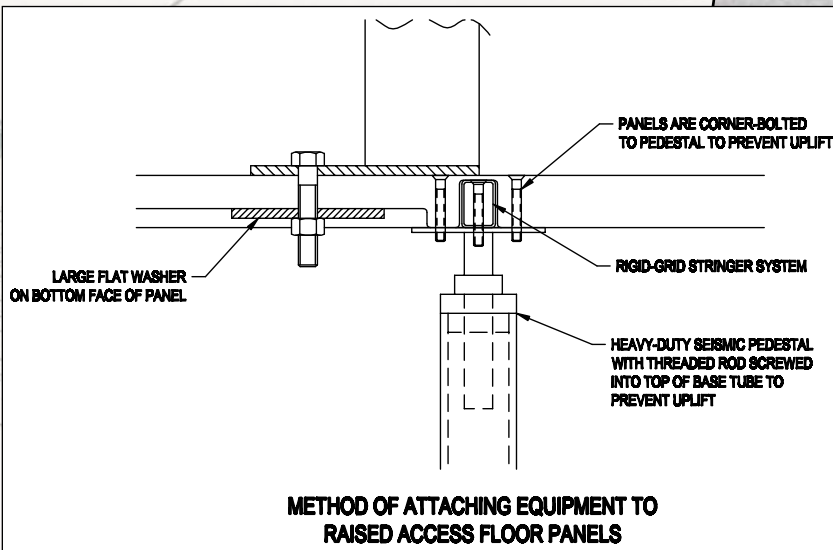

# ASM Raises the Bar Heavy Duty (H-D) Pedestal Systems

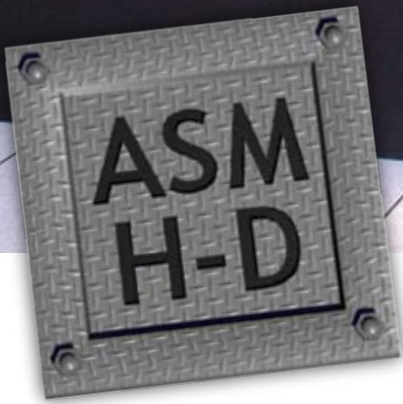

## ASM's Understructure

### Seismic Pedestals

ASM offers the most comprehensive variety of pedestal types, providing economical solutions for non-seismic to high seismic regions. This full line of pedestals can further be strengthened by bolting them to the concrete slab for the most solid access flooring systems available.



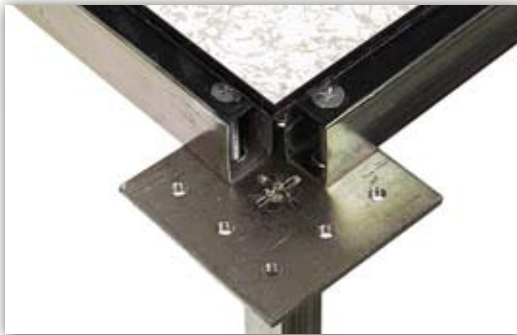

# Rigid Grid

Offering great lateral support, this system is generally used where the panels are gravity held on the understructure. Stringers are available in 2' (600 mm) and 4' (1200 mm) lengths allowing for standard (2' x 2'), (4' x 2') or (4' x 4') basketweave installations.



Every ASM stringer boasts solid tube construction to resist bowing and spreading during load impacts. A factory applied solid vinyl gasket creates a quiet fit between the stringer and panel.

**All of ASM's parts are Hot Dipped Galvanized "HDG" dipped in a corrosion-resistant, zinc whisker-resistant finish after stamping and welding, to protect welds and raw edges from rusting.**

-  All pedestals are dipped after stamping and welding to protect welds and raw steel edges against rust.
-  Versatile understructure for all types of installations.

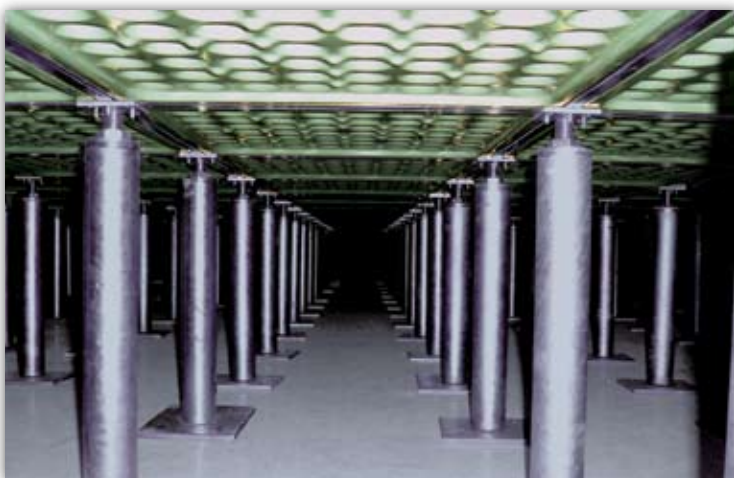

# ASM Smart-Trim (Patent Pending)

## Innovations in Access Flooring

### Smart-Trim Technology

**SMOOTH  
SEAMLESS  
WEARPROOF**

### A Breakthrough in Laminate Technology

**20% Better wear surface results than competition.**

- ☒ Revolutionary trim that is printed into the laminate under the high wear finish.
- ☒ No routing or removal of high wear surface.
- ☒ No exposed paper core to absorb dirt and moisture
- ☒ No recess or step down. Reduces chipping and caster noise. Eliminates dirt trap.
- ☒ No surface applied paint or inks - cannot wear off.

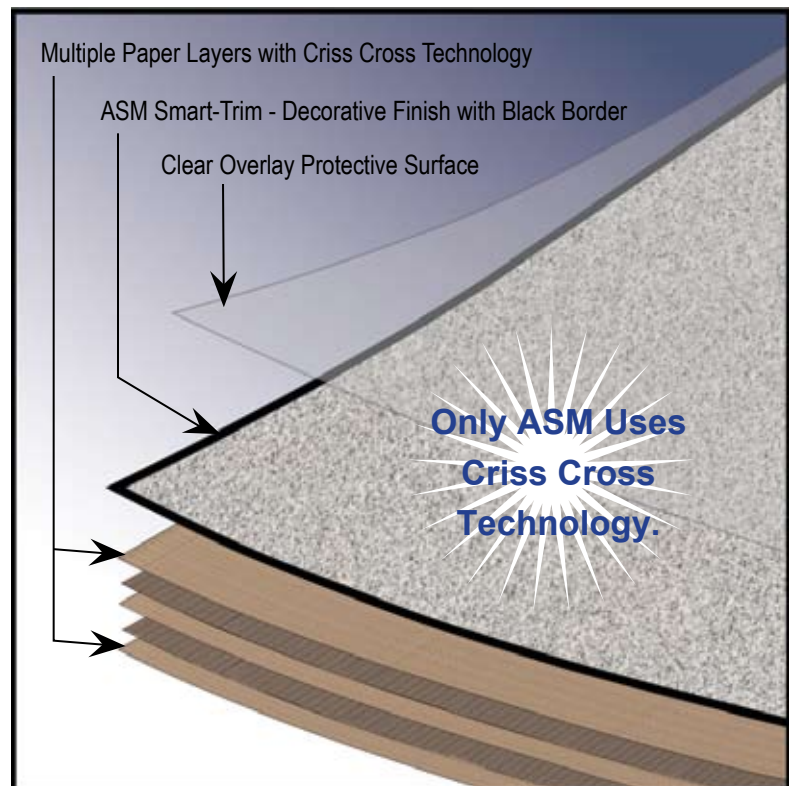
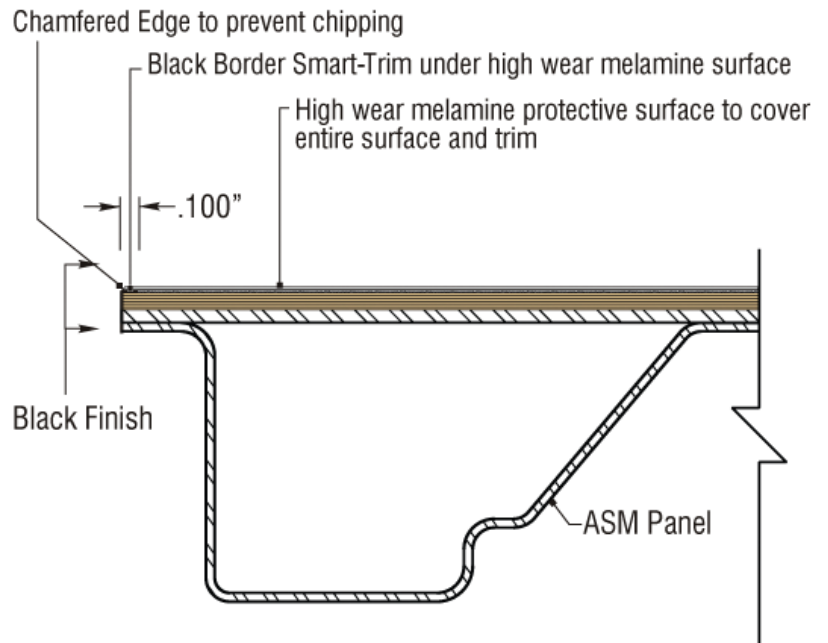

# ASM's Smart-Trim

- ❌ No dust
- ❌ No Exposed Paper
- ❌ Smooth Transition

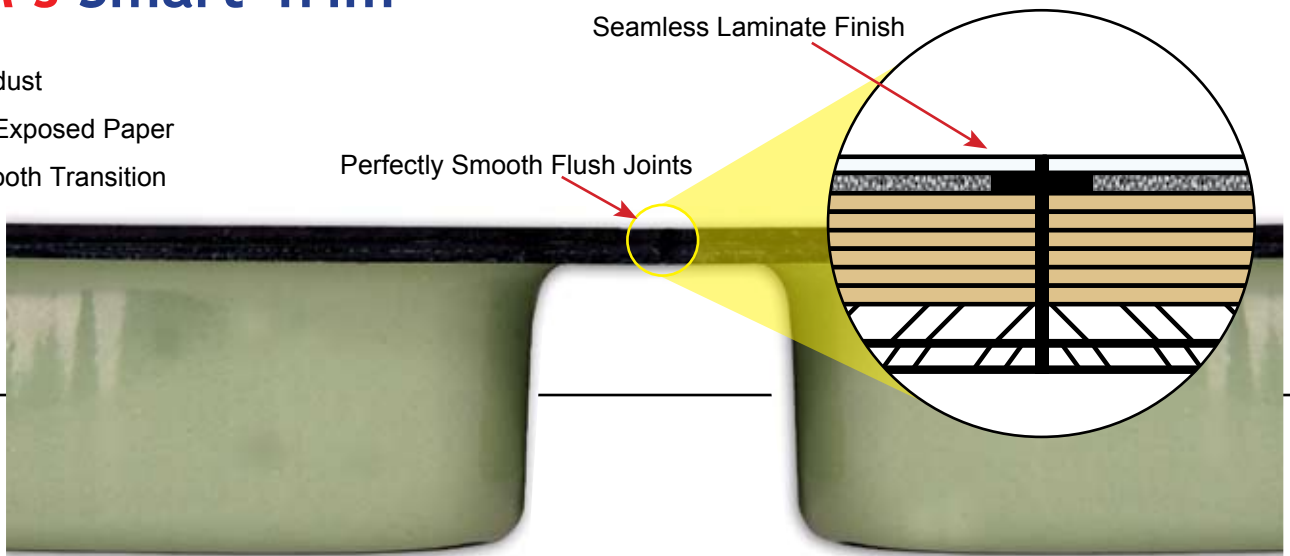

# Competition's Trim

## Competition's Trim creates:

- Dust accumulation
- No smooth transition
- Allows for moisture absorption
- Creates wheel chatter
- Rolling load hazards

Protective Overlay Surface  
Removed To Expose  
Paper Core

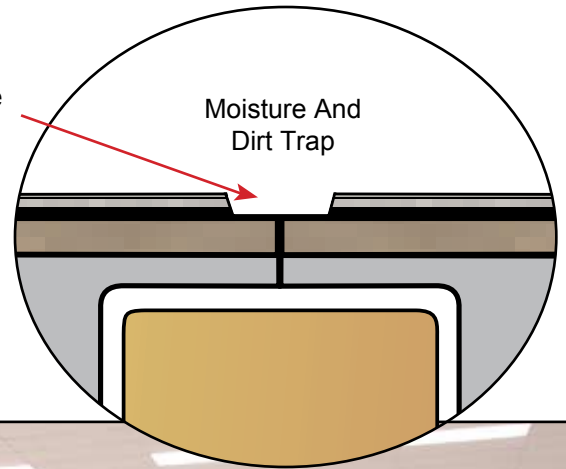

# ASM's Laminate

## with Platts Technology

### Designed Specifically for Raised Access Floors in Conjunction with Platts Laminate Technologies.

High pressure plastic laminate is used in 90% of all computer room applications, and is the largest product used on factory laminated floor finishes. Laminate is a one piece tile (24" x 24"), and unlike VCT, will provide a uniform finish with no joints. HPL has the advantage of not requiring wax or maintenance that could produce static problems in the data center.

“Optimized Resin Formulas And Press Time For The Best Performance.”

- F. Holbrook Platts

#### ASM Laminate Performance Specifications

Properties	NEMA Test Method	NEMA Standard	ASM Laminate Results
Electrical Resistance	NFPA 99	-	$1.0 \times 10^6 - 2.0 \times 10^{10}$
Stain Resistance	3.4	No effect	No effect
Boiling Water Resistance	3.5	No effect	No effect
High Temperature Resistance	3.6	Slight effect	No effect
Wear Resistance	3.13	3000 cycles(min.)	5000+
Scuff Resistance	3.16	No effect	No effect



ASM - 2201 - 1



ASM - 2202



ASM - 2203



ASM - 2204



ASM - 2205



ASM - 2206



ASM - 2207



ASM - 2208

### F. Holbrook Platts

Mr. Platts is the worldwide expert in industrial and decorative High Pressure Laminate Technologies and boasts over 40 years industry experience with industry giants Westinghouse (Micarta Division), International Paper and Nevamar. Mr. Platts also served on ASTM and NEMA standards and technical committees for the laminates and building products industries for over 30 years.









# ASM's Vinyl Plastic Technologies

The use of VPT conductive or static dissipative floor covering checks the influence of electrostatic charges in the sensitive work places. The effects of electrostatic influence is very serious, and many incidents include damage to integrated circuits in semiconductor production and loss of valuable data caused directly by a build up of static electricity.

Static discharge may also cause inadvertent ignition of flammable and explosive substances. When two objects with electrostatic charge come into contact, electron movement occurs with electrification to positive and negative poles which are stationary at the points of mutual contact.

Direct action against these points will cause instantaneous electric discharge, resulting in product damage, pollution or malfunction. Both UL and NFPA strongly recommend the use of conductive floor coverings for sensitive operations.

## Where VPT is recommended:

-  Electronic Manufacturing Facilities
-  Computer/Server Room Installations
-  Cleanrooms
-  Assembly Factories
-  Telecommunications Rooms
-  Healthcare Laboratories

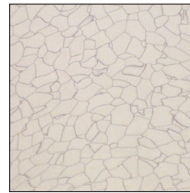

3160 Platinum

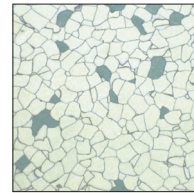

3161 Mint

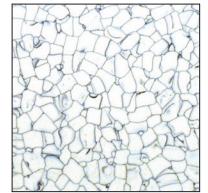

3162 White

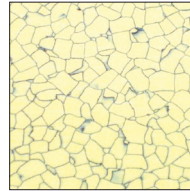

3163 Yellow

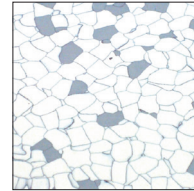

3164 Tundra

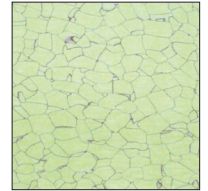

3165 Wintergreen

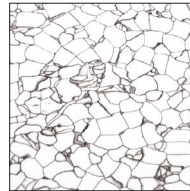

3166 Ice

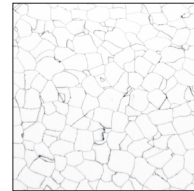

3167 Diamond

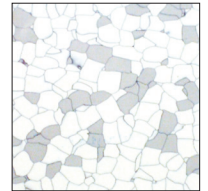

3168 Cloud

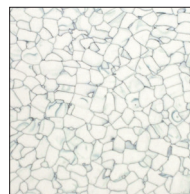

3169 Glacier

Superior polished finish that maintains its conductivity and appearance, in 10 NEW designer colors.

**Lifetime Conductivity Warranty.  
Resistant To Chemicals.**

Performance	Conductive	Static Dissipative
Resistance: point to ground	$2.5 \times 10^4$ to $10^6 \Omega$	$10^6 \Omega$ to $10^8 \Omega$
Resistance: point to point	$2.5 \times 10^4$ to $10^6 \Omega$	
Static Decay	5000 to 0 volts in $< 0.01$ sec	5000 to 0 volts in $< 0.2$ sec

## PGD Electrical Grounding Clip

Is your floor grounded? If there is electrical build-up or a grounding problem on top of the floor, it can cause major problems and shut down your system.

ASM is the only manufacturer to comprehensively address grounding problems by incorporating a solid brass Positive Grounding Device

(PGD patent pending) on every tile covered panel in a rigid grid system as standard equipment.

A small detail solves a critical problem. The PGD is not required for the Corner-Lock system as it has a 1/4-20 Fastener with paint cutting teeth for Positive Electrical Contact between panel and pedestal.



Patented PGD Grounding Clip supplied on all data center room panels

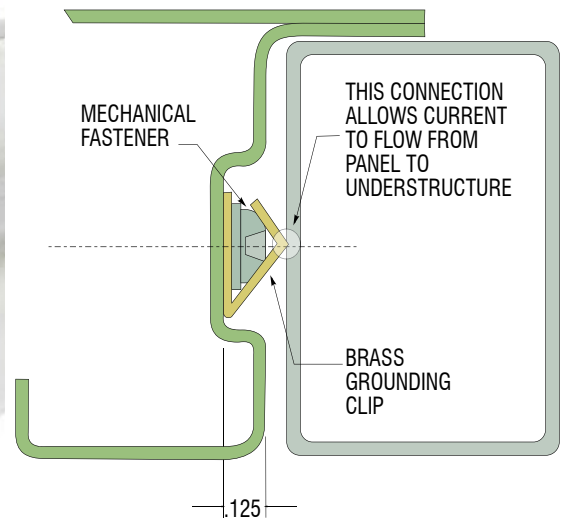

## Rigid Grid Understructure with Box Stringer

ASM's high strength stringers deliver unprecedented strength because of their unique solid tube design.

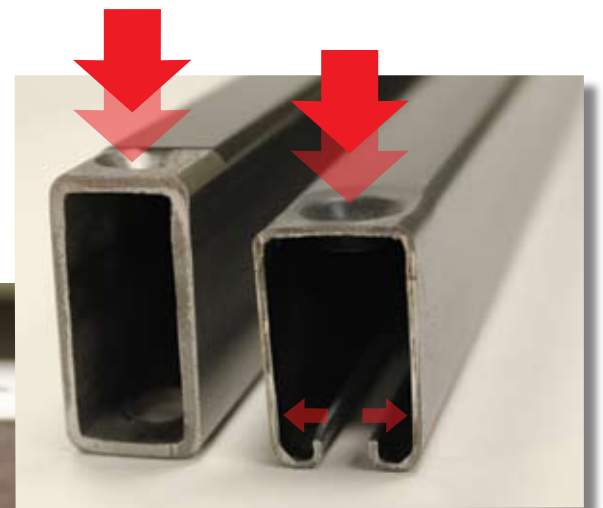

ASM's Solid Tube Design

Conventional U-shaped stringer

# ASM's Accessories

## Lifting Devices

ASM provides a variety of lifting devices, including double suction cup and airflow panel lifters - designed to make installations and alterations simple. They can be easily stored in Lifter Wall Mount Brackets.



## Grommets & Trims

Grommets and trims allow for simple connection of electronics through clean and attractive cut-outs. The face of the grommet slides to provide for cable adjustment.



## ASM's Seismic Braces

For those highest risk seismic projects, ASM offers one, two, three and four leg seismic braces that can easily be attached to any ASM pedestal for ultimate lateral support.

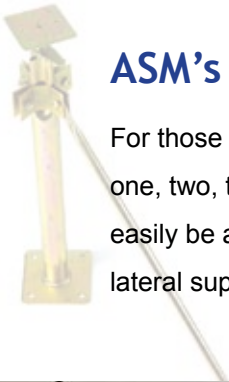

## Quick-Link Voice/Data Systems

Engineered using a completely portable "zone" approach, modular wiring can be adapted and changed easily, and without disturbances to phones, computers, and power to other users on the system. Quick and convenient changes and expansions can be a huge cost savings of the life-cycle of a building.

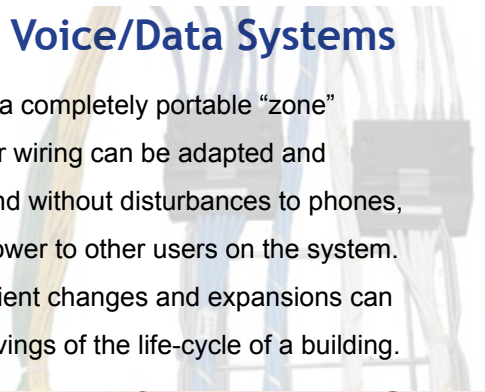

## Cable Tray

**Underfloor Cable Tray System** provides maximum accessibility and flexibility for your raised floor cabling needs.

### Self Supporting

Patented vertical support that does not compromise raised floor support weight limitations or warranties.

### No Stringer Types to Consider

Cable tray system is not suspended from tile stringers - it is independently supported, meaning no variables or regulations to consider.

### Easy Drop-In Design

Cable tray components are designed to fit 24" raised floor designs - just drop through tile space and lock into place - no fastening required. No cutting or splicing needed.

### Add More Cable Tray Easily

Additional runs and layers of cable tray can easily be added or changed without waste, demolition or lost time.

### Multiple Tray Sizes

24, 12 and 6 inch standard sizes. Others available upon request.



In addition to being the largest access flooring manufacturer in the world, the Kingspan group is a major manufacturer of an integrated range of products for the construction industry. The Group continues to innovate and improve on an existing product range, and have done so successfully for over 30 years. These innovations are clearly seen within Kingspan's emphasis on Modern Methods of Construction and importance on increasingly sustainable buildings.

The Group's companies have a presence around the world that is ever increasing.

**For more information about Kingspan please visit us at [www.kingspan.com](http://www.kingspan.com).**



## *Green Building Technology*

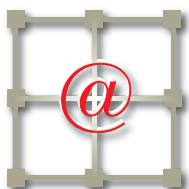

**ASM**  
innovations in access flooring

9500 Industrial Center Drive  
Ladson, South Carolina  
29456  
(843) 534-1110  
(843) 534-1111 Fax

**[www.asmproducts.com](http://www.asmproducts.com)**

